

FENIX G56.2

FENIX

G56.2

July 2023



FENIX G56.2

G56.2 is a high-competition, high-quality, 1/10-scale model car intended for persons aged 16 years and older with previous experience building and operating RC model racing cars. This is not a toy; it is a precision racing model. This model racing car is not intended for use by beginners, inexperienced customers, or inexperienced racers or by children without direct supervision of a responsible, knowledgeable adult.

Before building and operating your G56.2, YOU MUST read through all of the operating instructions and instruction manual and fully understand them to get the maximum enjoyment and prevent unnecessary damage. Read carefully and fully understand the instructions before beginning assembly.

Contents of the box may differ from pictures. In line with our policy of continuous product development, the exact specifications of the kit may vary without prior notice.

Take appropriate safety precautions prior to operating this model. You are responsible for this model's assembly and safe operation! Please read the instruction manual before building and operating this model and follow all safety precautions

IMPORTANT NOTES – GENERAL

- This product is not suitable for children under 16 years of age without the direct supervision of a responsible and knowledgeable adult.
 - Carefully read all manufacturers warnings and cautions for any parts used in the construction and use of your model.
 - Assemble this kit only in places away from the reach of very small children.
 - First-time builders and users should seek advice from people who have building experience in order to assemble the model correctly and to allow the model to reach its performance potential.
 - Exercise care when using tools and sharp instruments.
 - Take care when building, as some parts may have sharp edges.
 - Keep small parts out of reach of small children. Children must not be allowed to put any parts in their mouth, or pull vinyl bag over their head.
 - Read and follow instructions supplied with paints and/or cement, if used (not included in kit).
 - Immediately after using your model, do NOT touch equipment on the model such as the motor and speed controller, because they generate high temperatures. You may seriously burn yourself seriously touching them.
 - Follow the operating instructions for the radio equipment at all times.
 - Do not put fingers or any objects inside rotating and moving parts, as this may cause damage or serious injury as your finger, hair, clothes, etc. may get caught.
 - Be sure that your operating frequency is clear before turning on or running your model, and never share the same frequency with somebody else at the same time. Ensure that others are aware of the operating frequency you are using and when you are using it.
 - Use a transmitter designed for ground use with RC cars. Make sure that no one else is using the same frequency as yours in your operating area. Using the same frequency at the same time, whether it is driving, flying or sailing, can cause loss of control of the RC model, resulting in a serious accident.
 - Always turn on your transmitter before you turn on the receiver in the car. Always turn off the receiver before turning your transmitter off.
 - Keep the wheels of the model off the ground when checking the operation of the radio equipment.
 - Disconnect the battery pack before storing your model.
 - When learning to operate your model, go to an area that has no obstacles that can damage your model if your model suffers a collision.
 - Remove any sand, mud, dirt, grass or water before putting your model away.
 - If the model behaves strangely, immediately stop the model, check and clear the problem.
 - To prevent any serious personal injury and/or damage to property, be responsible when operating all remote controlled models.
 - The model car is not intended for use on public places and roads or areas where its operation can conflict with or disrupt pedestrian or vehicular traffic.
 - Because the model car is controlled by radio, it is subject to radio interference from many sources that are beyond your control. Since radio interference can cause momentary loss of control, always allow a safety margin in all directions around the model in order to prevent collisions.
 - Do not use your model:
 - Near real cars, animals, or people that are unaware that an RC car is being driven.
 - In places where children and people gather
 - In residential districts and parks
 - In limited indoor spaces
 - In wet conditions
 - In the street
 - In areas where loud noises can disturb others, such as hospitals and residential areas.
 - At night or anytime your line of sight to the model may be obstructed or impaired in any way.
- To prevent any serious personal injury and/or damage to property, please be responsible when operating all remote controlled models. Failure to follow these instructions will be considered as abuse and/or neglect.
- We have made every effort to make these instructions as easy to understand as possible. However, if you have any difficulties, problems, or questions, please do not hesitate to contact the Fenix support team at racing@fenixwaterjet.com . Also, please visit our Web site at www.Fenix-racing.com or www.fenixracingshop.com or <https://www.facebook.com/FenixRacing.it/> or <https://www.facebook.com/FenixRacingOriginal> the latest updates, set-up information, option parts, and many other goodies. We pride ourselves on taking excellent care of our customers.

Carbon Nut assembly

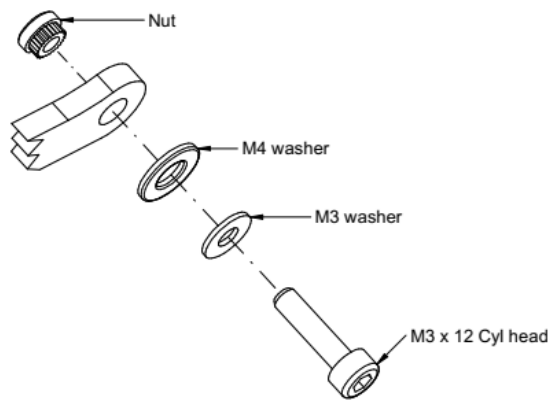

----- **Read me first!!!** -----

G56.2 use this kind of special nut in several places. Just take your time and the result will be great.

Those comes already pre-assembled, but is always good to know "how to", just in case of...

To insert the Nut in the carbon fibre you have to follow this easy procedure.

Slide the M3 and M4 washer over the M3 x 12 Socket Head Screw.

Insert the screw in the carbon part and tight by hand the special nut.

Once the nut hit the carbon fibre it will start to secure itself into the CF.

Tighten it slowly (very slowly) until it stops.

Don't overtight it – is completely unnecessary

Tip 1:

You might want to slightly chamfer the Top face with your body reamer. Just enough to remove the sharp edge

Tip 2:

When the nut hit the carbon fibre, before insert it fully, you can add a tiny drop of thin slow cure CA glue. *Very tiny....*

Tip 3:

Don't use electric tools to drive the screw, most likely you'll end damaging the carbon fibre....

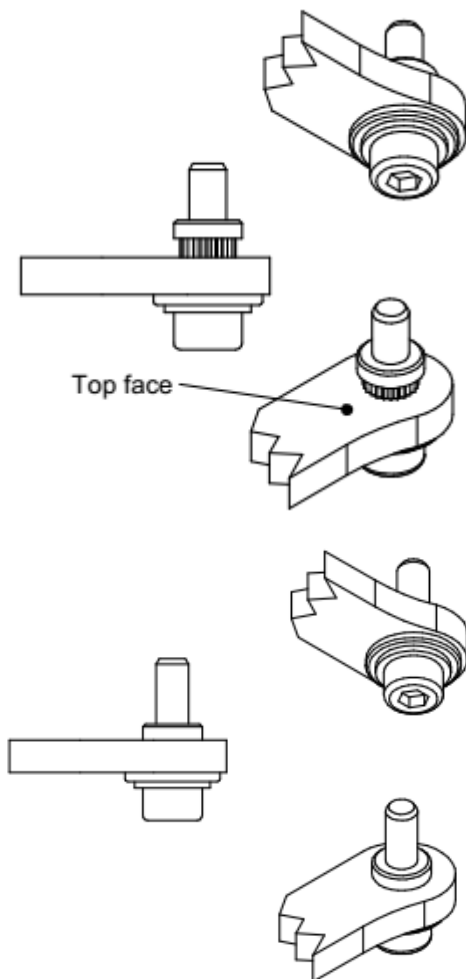

FENIX G56.2

Bag A

Front end

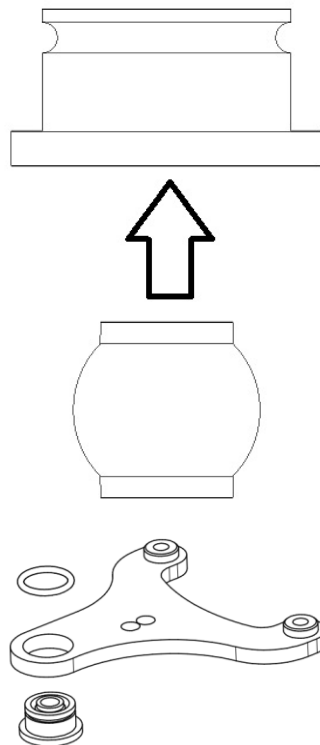
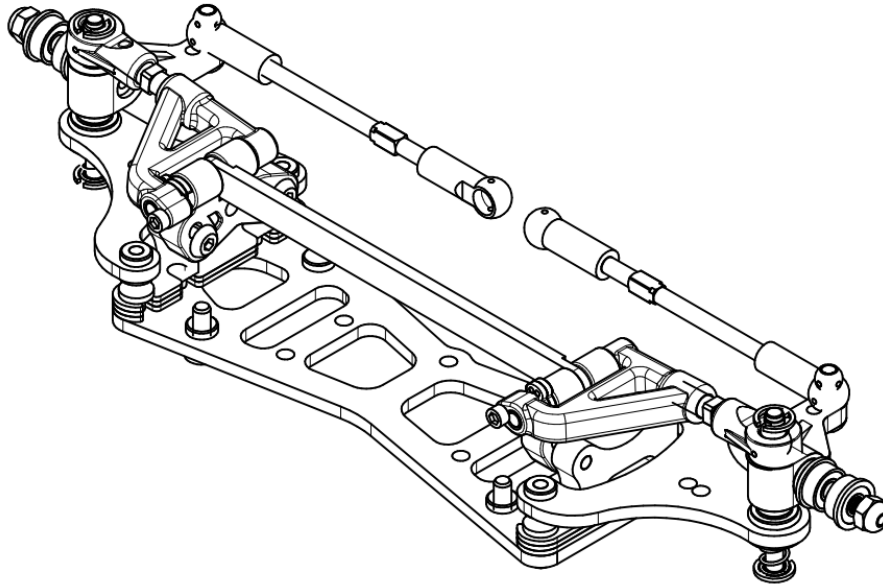

2 x G56038 Sphere holder
2 x M20-K3 6mm sphere

Make 2 sets

Insert the group into the G562-11 front arm –

Fix the sphere holder with the provided O-ring

Make 2 mirror sets.

Note: Be sure that the sphere holder fit easily, you might have to enlarge the hole with some sandpaper.

FENIX G56.2

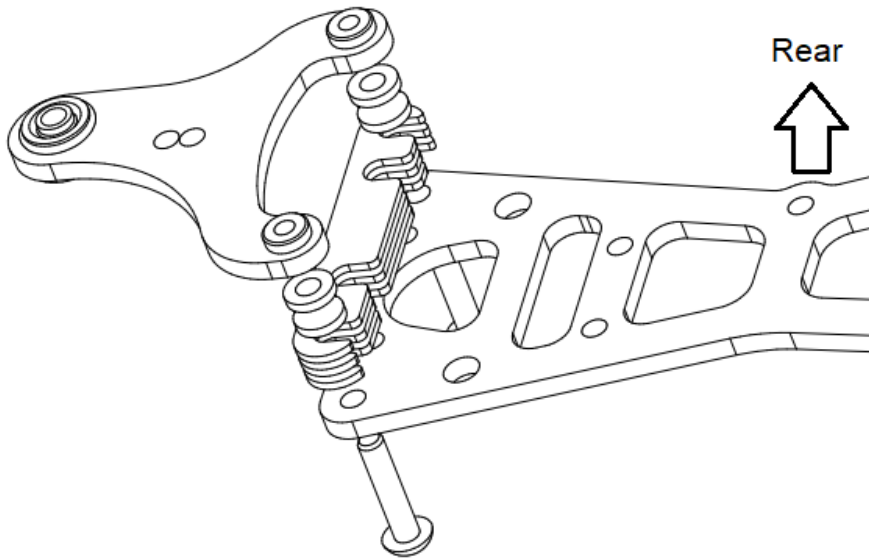

Insert the OPT-038 Oring around the sphere holder.

Insert 2 HW030 M3x16 button screw into G562-10.

Insert 2 FX088 over the screw and tight the lower arm.

Use the provided G562-14 shims to adjust the front ride height.

Make 2 sets mirror like

See note1

Rear of the car

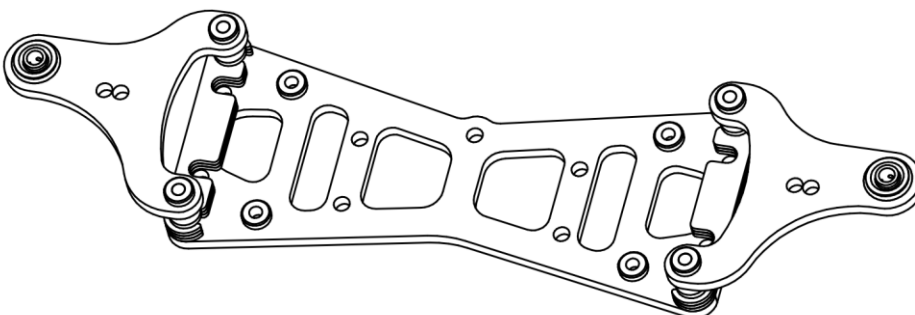

Front-end should look this way

Front of the car

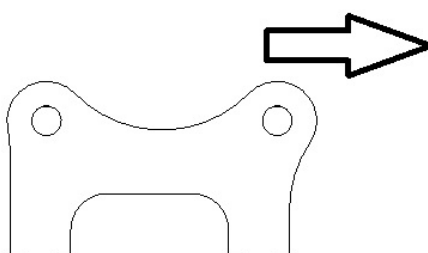

Take care of the direction for G56-039 . The arrow is toward the front of the car.

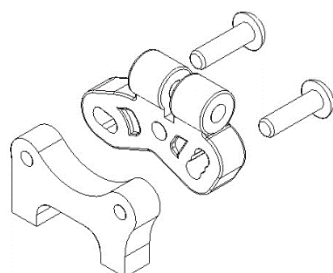

Secure the G56-030 upper arm mount to the G56-039 using 2 HW004 M3x10mm Hex button screw.

You have to prepare 2 mirror sets.

FENIX G56.2

Install the 2 arm holders using 4 x HW004 M3x10 button screws.

See Note 1

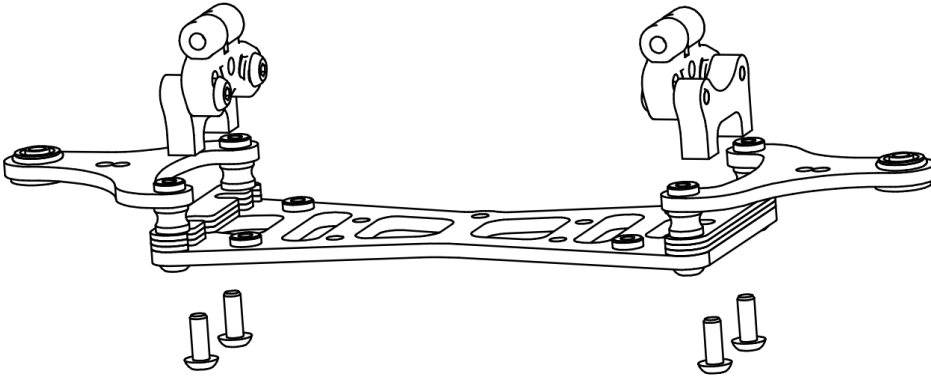

According to the numbers of G562-14 Shims you're using in your setup, the screw used to assemble the lower arms and the arm holder might have to be replaced with shorter ones

Note 1

Active caster settings.
5 Degrees are default setting.

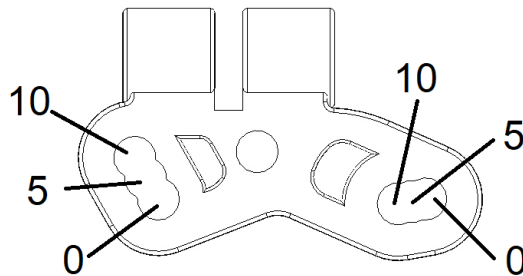

G56-031 arm –
G56-033 eyelet-
G56-032 turnbuckle
G56-037 sphere

Make 2 sets

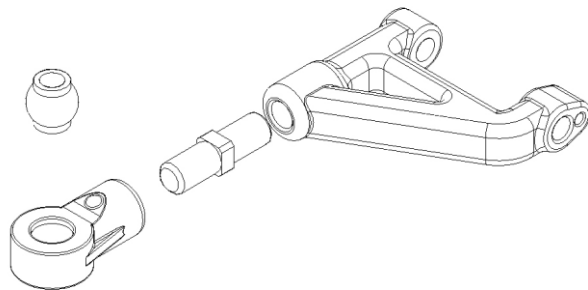

Slide the G56-013 front beam into the upper arm mounts, then insert the G56-034 hinge pins and secure them with the HW031 M2x4 screw

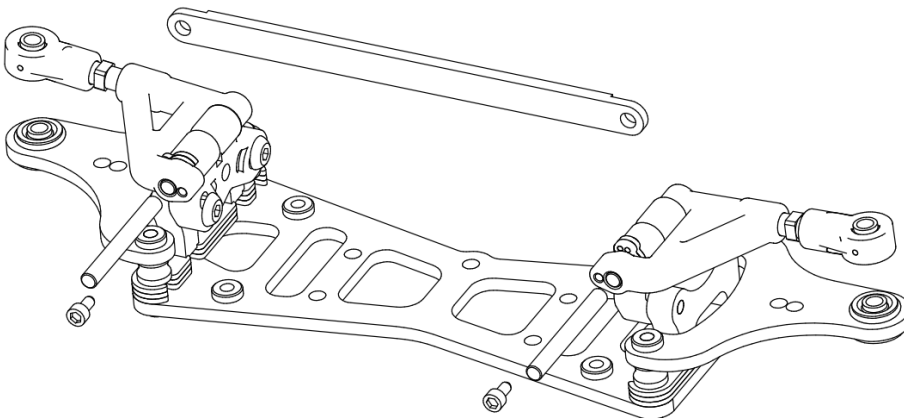

FENIX G56.2

Make 2 sets

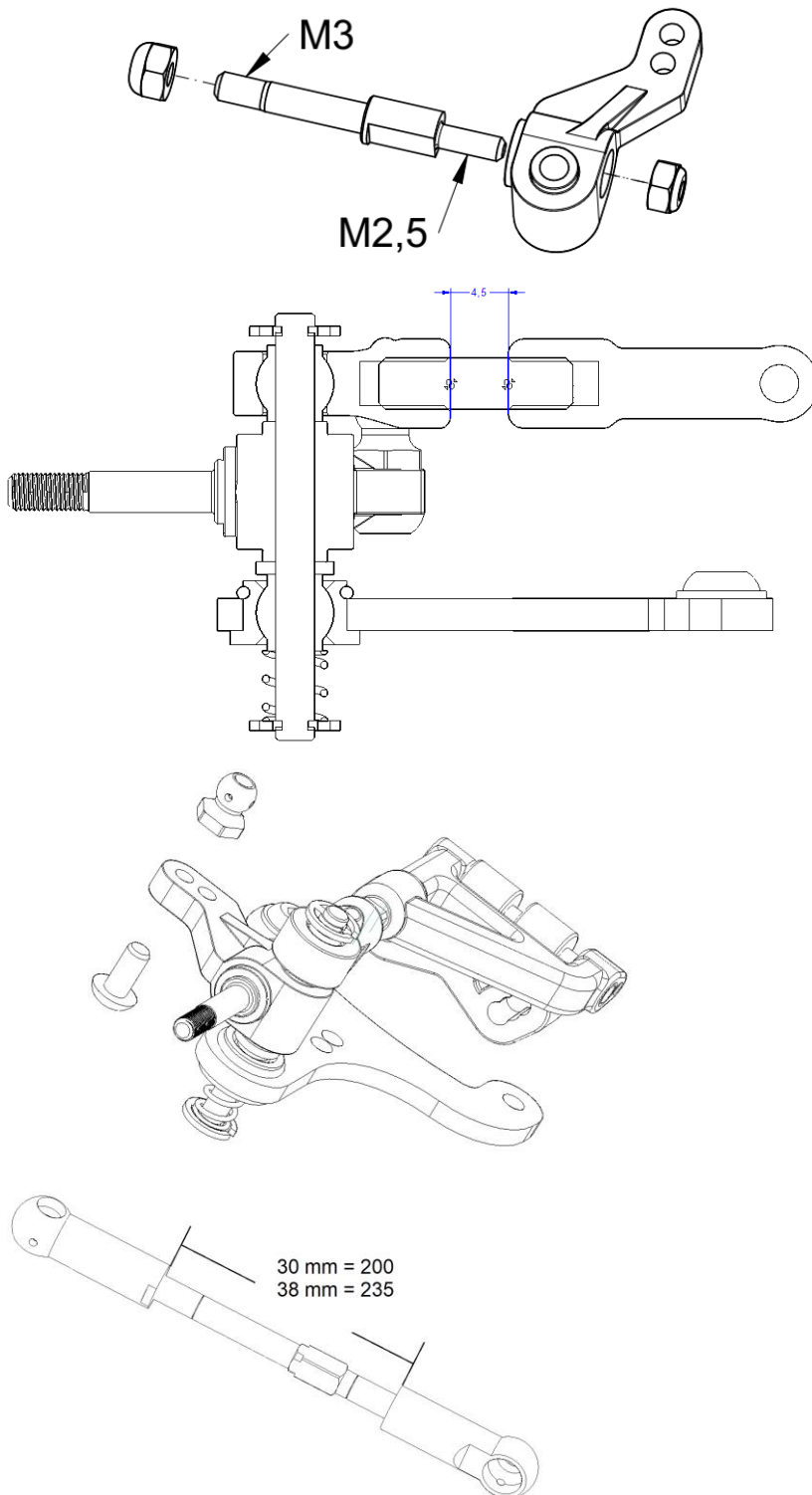

Set the distance at 4.5mm.

The proper camber setting should be set with the car ready to run.

Slide the kingpin and spring as shown, close them with the seeger ring

Assemble the FU-FX48 ball stud using the HW-003 M3x8 button screw as shown.

The dimension shown is a starting point, final refinement will be done while setting the model
Make 2 sets

FENIX G56.2

Bag B

Servo Holder

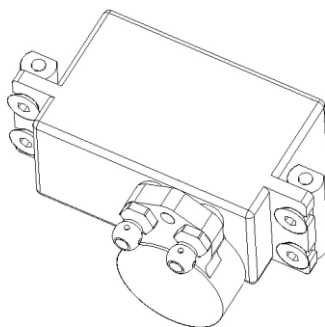
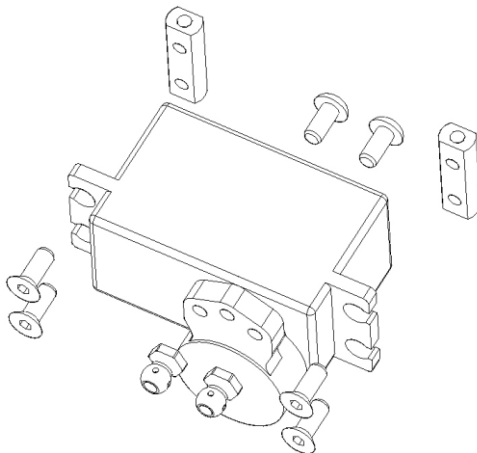
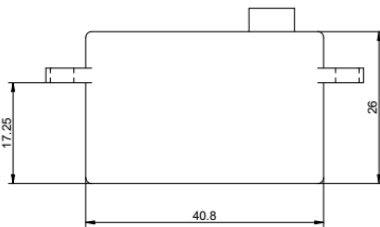
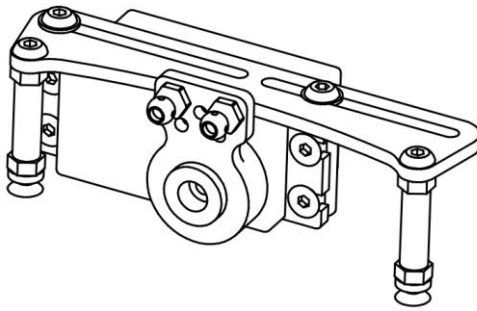

Servo and servo saver are not included, G56.2 need a low profile servo.

Note the dimension of the servo suggested

Use the 2 x HW003 M3x8mm button to secure the FX-FU48 to the servo saver.

Use the 4 x HW008 M3x8 countersunk screw to fix the FX022 servo mount

Assembled group. Servo saver should be vertical when servo is neutral.

FENIX G56.2

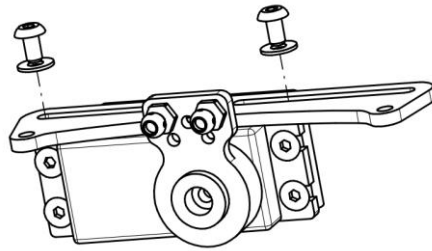

Using the 2 x HW0018 washer and 2 x HW008 M3x6 Button, fix the servo group to the G562-31 servo holder

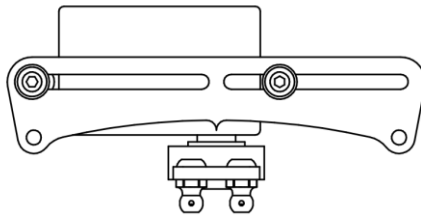

Trick!
Use the arrow in the servo holder to center the servo.

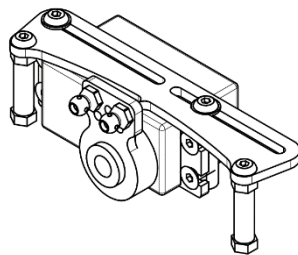

Fix the 2 x FX0052 20mm post to the servo holder using 2 x HW003 M3x8 button screw

Keep the provided 2 x 1.5mm shims and screws for a further step

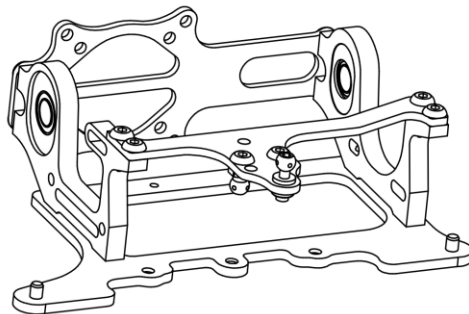

Bag C

Motor pod

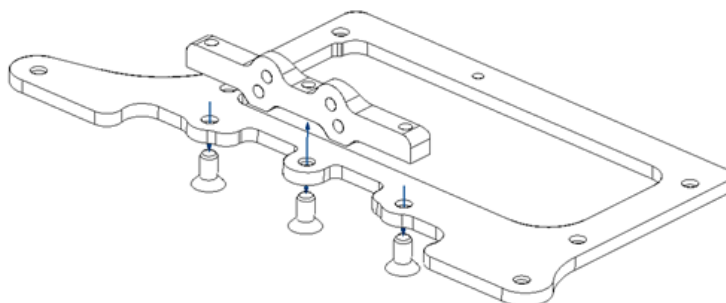

Using 3 x HW012 M3x6 countersunk screw to fix the V-link2 to the motor pod

FENIX G56.2

Insert 2 Fx0061-M ball studs in the V-link2

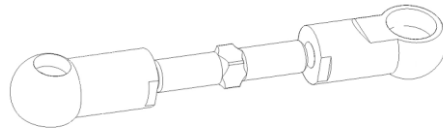
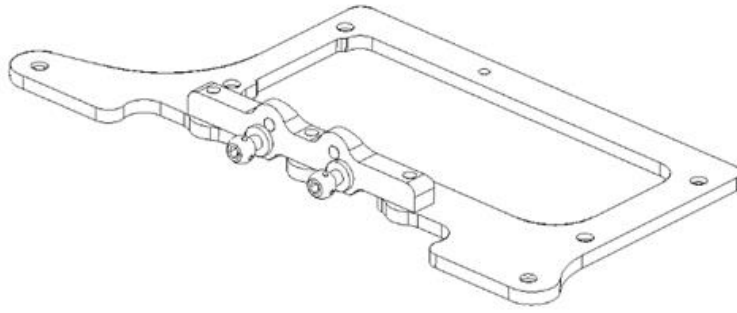

Build 2 sets of links using 2 x TR15 and 4 FX0037 - short

Use this dimension as reference. Later you'll have to fine tune it.

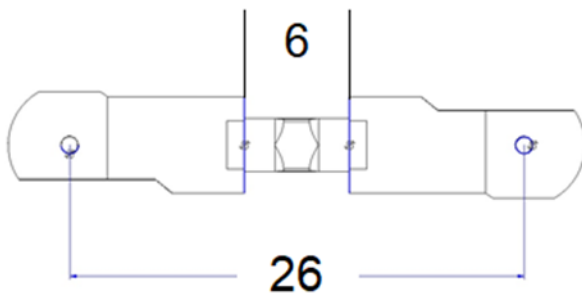

Fix the link over the V-link2

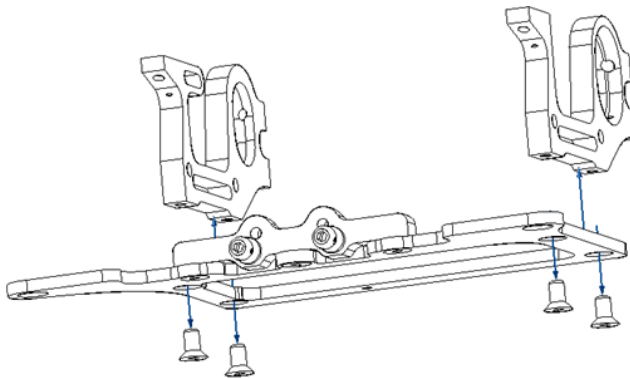

Using 4 x HW012 M3x6 countersunk screws, fix the motor holder and left bulkhead to the motor pod. Tight the screws evenly using an "X" pattern

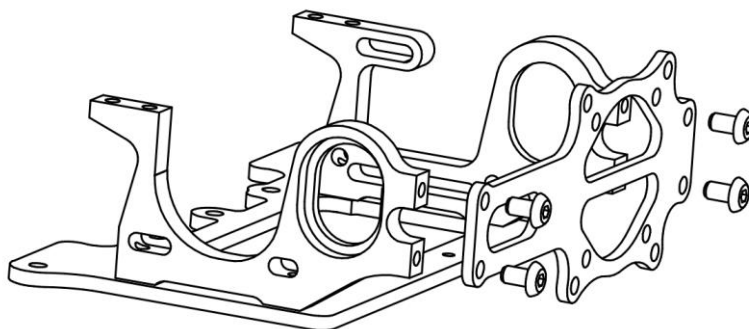

Fix the G562-201 brace to the group using 4 x HW008 M3x6 button screw. Tight the screws evenly using an "X" pattern

G562-201 brace can be used to fix a 30*30mm or 40*40mm fan.
Note, according the fan you choose, you might have to add some shims between the brace and the uprights.

Note 1

FENIX G56.2

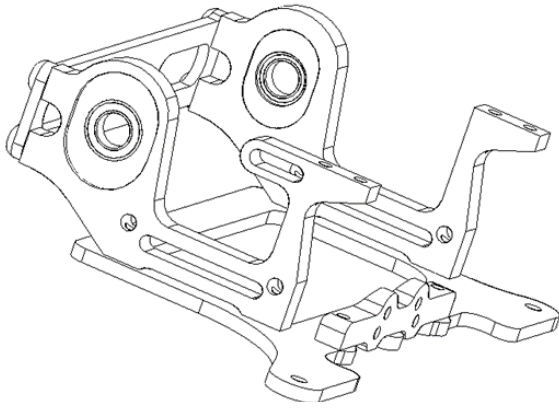

NOTE:
ride height adjuster might require
some sanding for an easy fit.

Insert the ride height
adjuster and the
flanged bearings (Axle
bearings are located in
the differential bag)

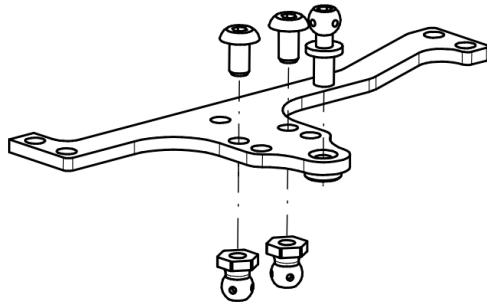

Install the FX-FU48
and the Fx0061-M

Wait to install the
shock holder to the
motor group.



*How about a cup of coffee now?
You deserve it!*

*And... while you drink your coffee, you can start to familiarize
with the V-link setting...*

Just scan the QR



Bag D

Chassis

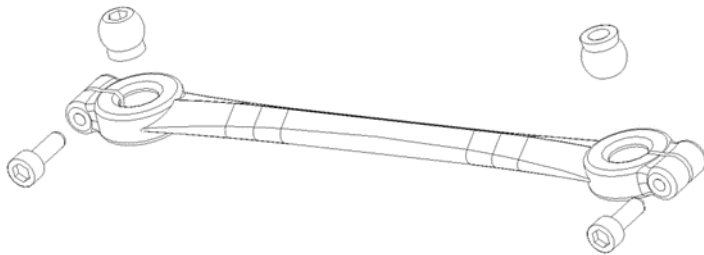
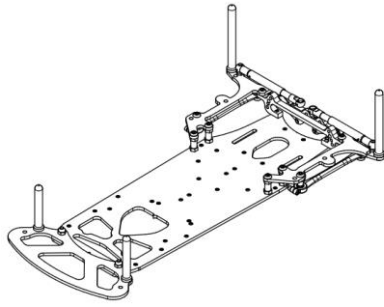

Use M3x8 grub screw

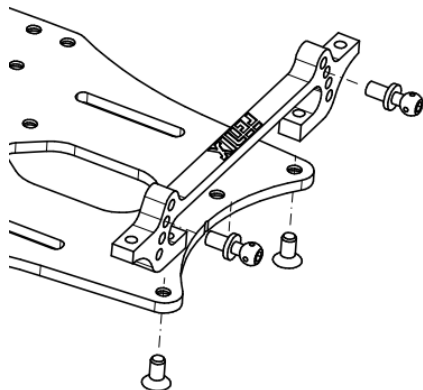
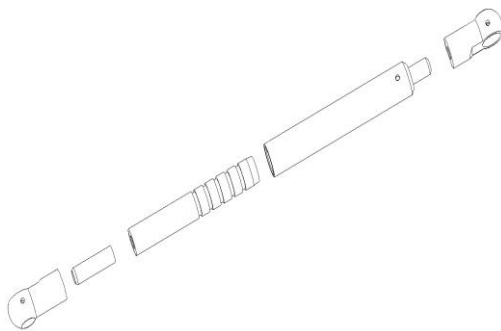

Prepare 2 sets –

Use 2 x HW0014 M2x 6 screws and 2 x FX002 spheres each

Note: the position of the spheres
Prepare 2 side spring set as shown.

Assembly the 2 side dampers as shown.
Use 30k syrup as starting point (not included)

Note: use the FX0037 short in the piston and the long one in the body of the damper

Assembly the M20 V-link1 to the chassis, using 2 x HW012 M3x6 countersunk screw.

Install the FX0061-M in the M20 V-link1 as shown.

FENIX G56.2

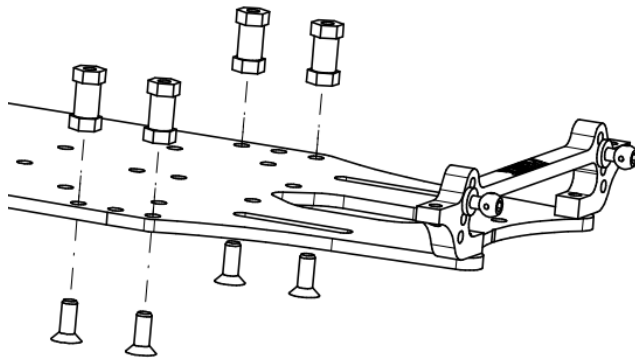

Use 4 x FX0052 12mm post, 4 x HW007 M3x8 countersunk screw and assembly as shown.

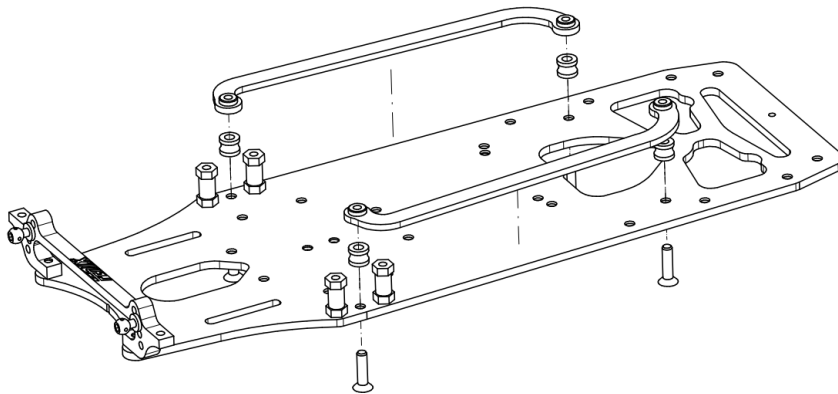

Locate the appropriate stiffener in the chassis bag.

Assemble it in the chassis as shown, using 4 x HW026 M3x12 countersunk screw, use the provided 5mm spacer FX0088

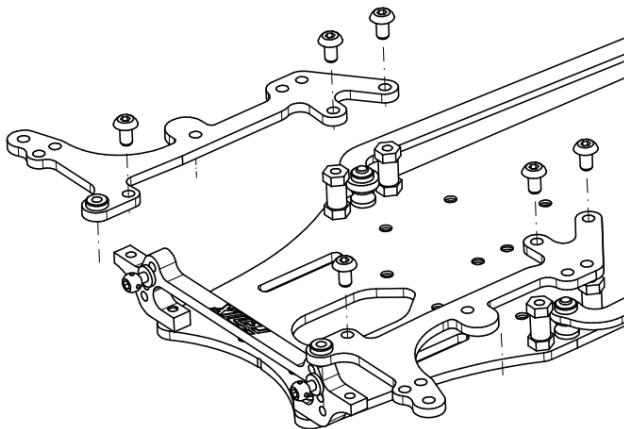

Using 6 x HW008 M3x6 button screws fix the 2 X G562-004 side wings on the 12mm posts and on the M20 V-Link1

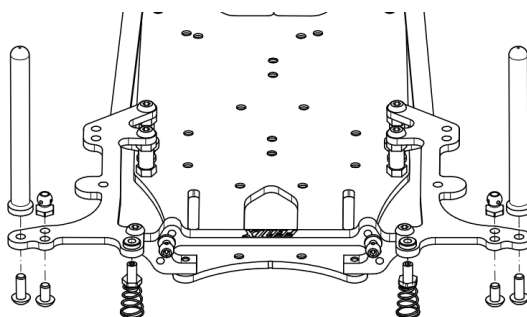

Assemble the FX-FU48 using 1 x HW008 3x6 button screw and the body post using 1 x HW007 3x8 button screw

The side spring has to be inserted into the M3 Carbon nut

FENIX G56.2

Note the option for side links and damper.

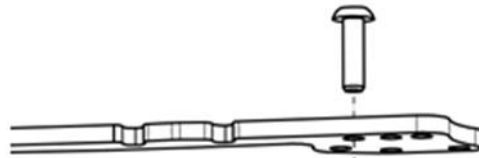
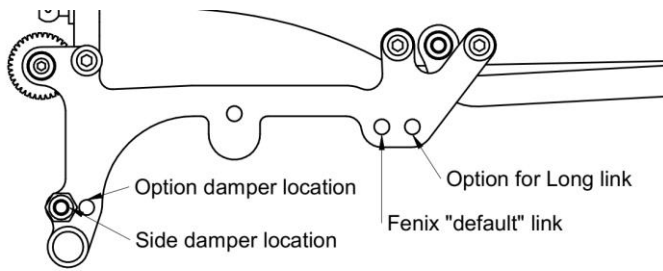

Insert the HW0029 M3x12 in the proper hole, then slide the G56-42-A spacer and the 1.5mm shim
Install the link assembled previously

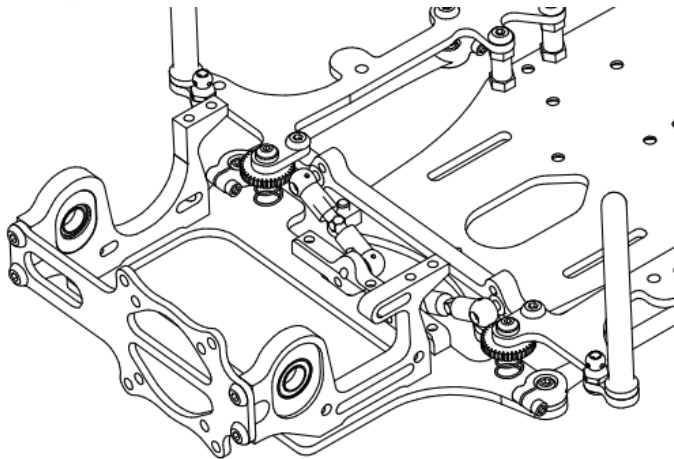

Fix the short link between M20 V-link1 and M20 V-link2

Using 2 x HW006 M3x6 countersunk screw (from bag C), you can now install the link to the motor pod group.

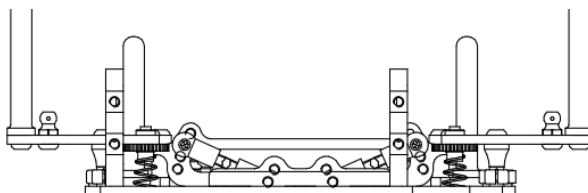

Now, lay the car on a flat setup board and make the final fine tuning of the links length.

Check our channel on Youtube for some explicative video.
<https://www.youtube.com/channel/UCDZqN09hr2Eal7qHCMjUciQ>



Chassis and motor pod must lay flat on the setup board.

Take the proper time for this setting.

FENIX G56.2

Install now the 2 dampers.

Intall the shock holder... you've prepared already.

It was in Bag-C parts...

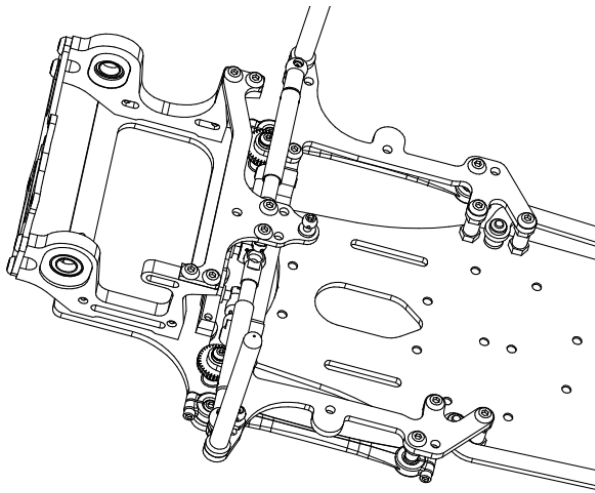

Start now with the front body post holder G562-003.

Install the front body post with 2 M3x8 HW007 countersunk screws.

Install the G562-002 bumper to the main chassis.

Install the front post holder over the bumper.

Fix them using 2 M3 x12 HW026 and 2 M3 Nylock HW027

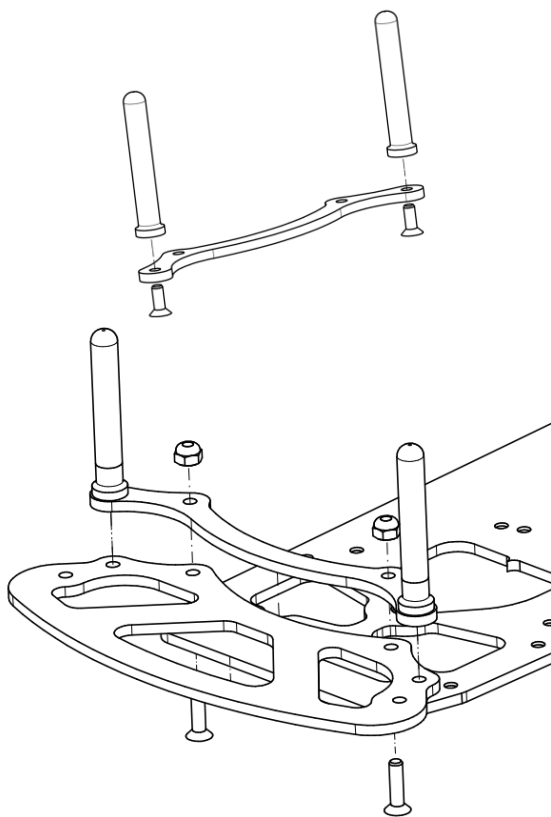

Install the front end group over the chassis, using 4 M3x10 HW033.

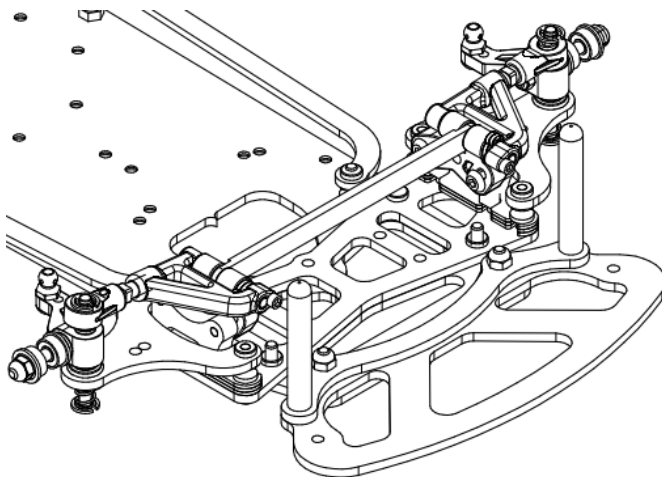

FENIX G56.2

Install now the servo group using 2 M3x8 Hw007, use the provided 1.5mm shims, over the screws.

Install the steering turnbuckles as well

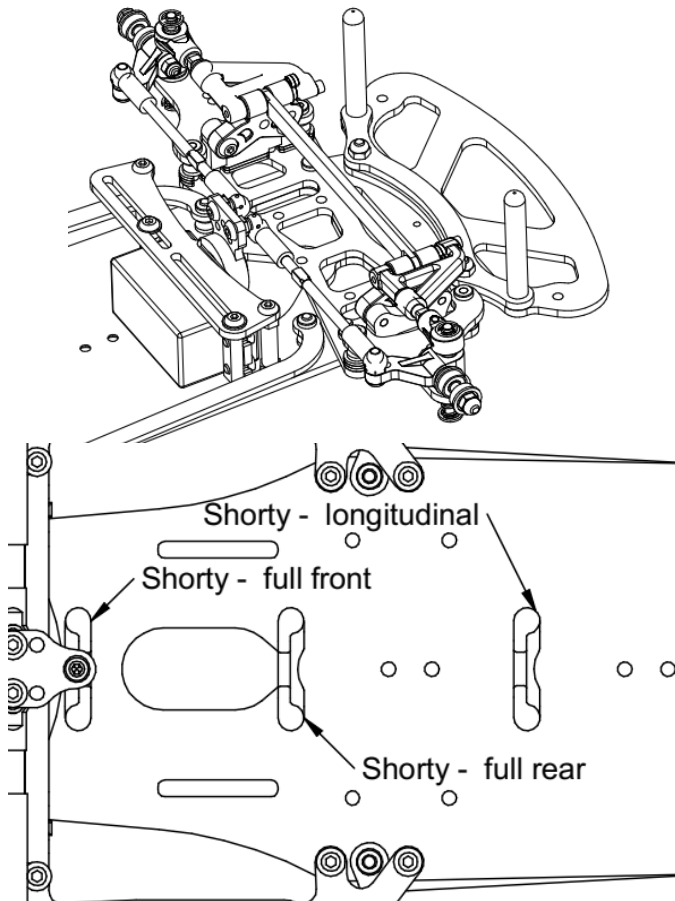

There are 3 possible position for Shorty Lipo:

Longitudinal
Fully rearward
Fully frontward
(7mm) difference

Use G562-300 to set the proper position.
Fix it with 2 x M3x6 HW012

FENIX G56.2

Bag E

Shock holder

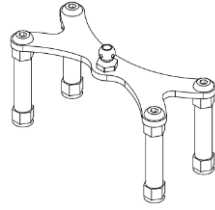

There are 2 shock holder options, according your lipo setting.
Note: some parts are omitted for sake of clarity.

Note 1

Cross Lipo

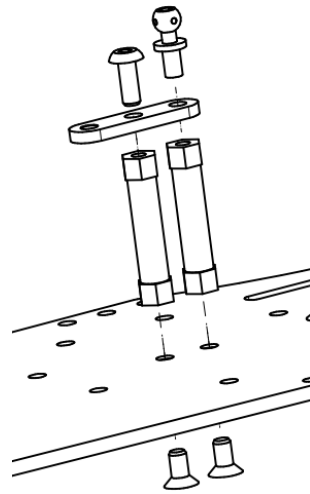

Note:
The countersunk hole should point to the front of the car, lower face.
Longitudinal Lipo

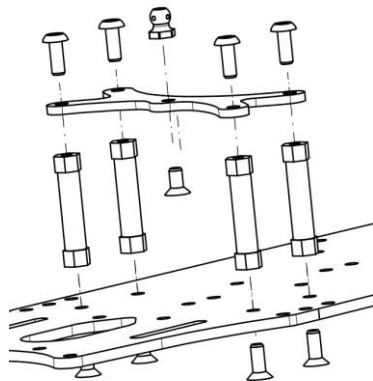

Fix 2 FX0054 26mm posts to the chassis using 2 M3x6 HW012 screws

Then install the M33-7 shock holder using 1 M3x8 HW008 screw in the center hole and 1 FX0061 male stud in the rear hole.

Fix 4 FX0054 26mm posts to the chassis using 4 M3x6 HW012 screws

Then install the G562-005 shock holder using 4 M3x8 HW008 screws.

Fix the FX-FU48 using 1 x M3x6 HW012.

FENIX G56.2

Note the position of the holder.

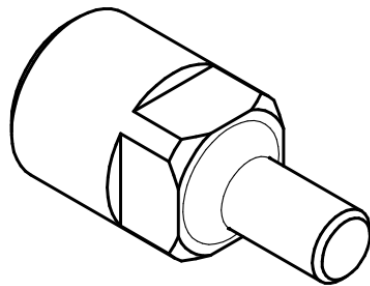
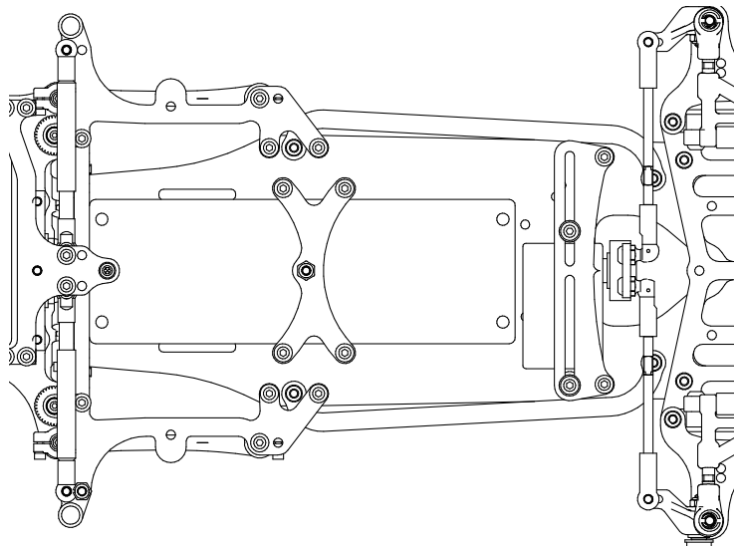
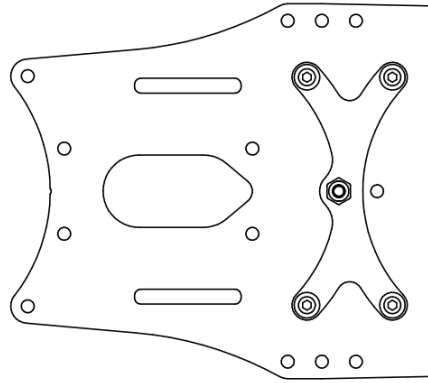

Note 2

Long lipo (touring) are possible only with low profile servos.

There are 2 shock holder options, according your lipo setting.

The M20-K7 shock adjuster will be used to adjust the motor pod droop.

FENIX G56.2

Shock Bag

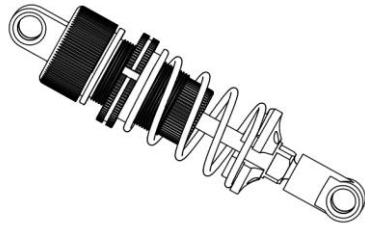

(soft) Red - Yellow - Blue - White - Black (hard)
2 - 3 - 4 Cylindrical holes * 2- 3 - 4 Conical holes

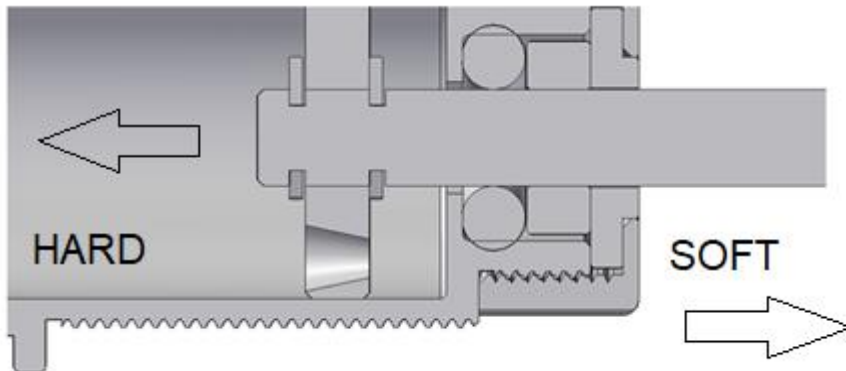

Springs supplied
Pistons supplied

Take care when
using conical pistons
as shown.

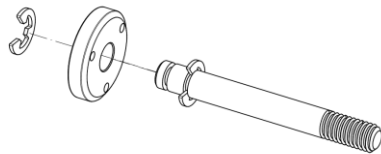

Start assembling the
piston . 4 holes .

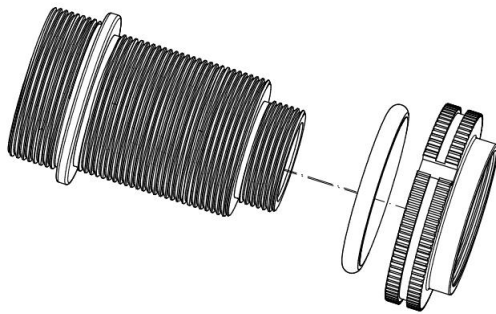

Lubricate and insert
the o-ring into the
setting ring.

Slide the setting ring
over the shock body.

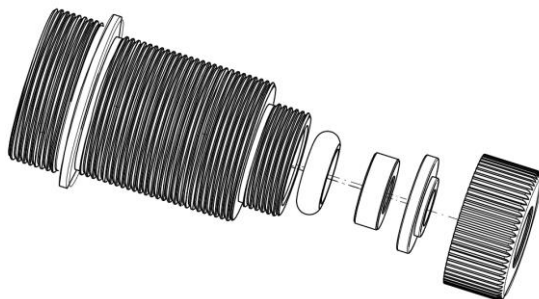

Lubricate the o-ring
and guide ring with
shock oil or
differential grease

FENIX G56.2

Screw together the M20-K7 droop adjuster and the ball joint (short)

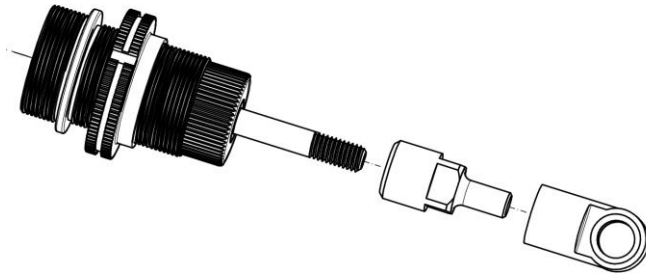

Fill the shock absorber with your favourite oil...

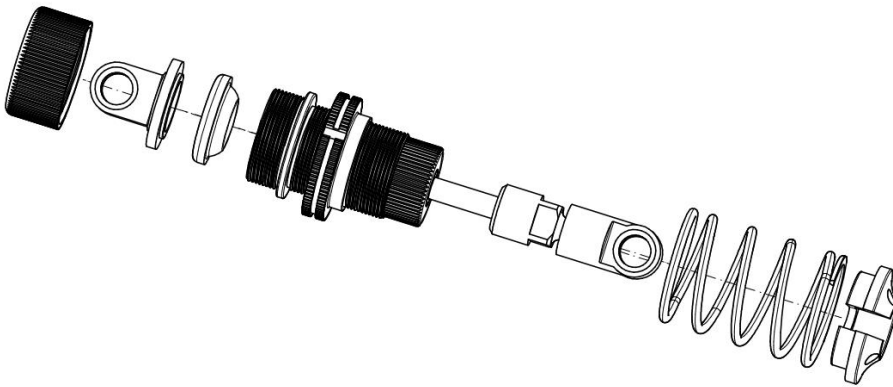

Close the shock absorber with rubber seal, ball joint and cap.

Slide the spring and spring holder in position.

Blue spring is a good starting point.

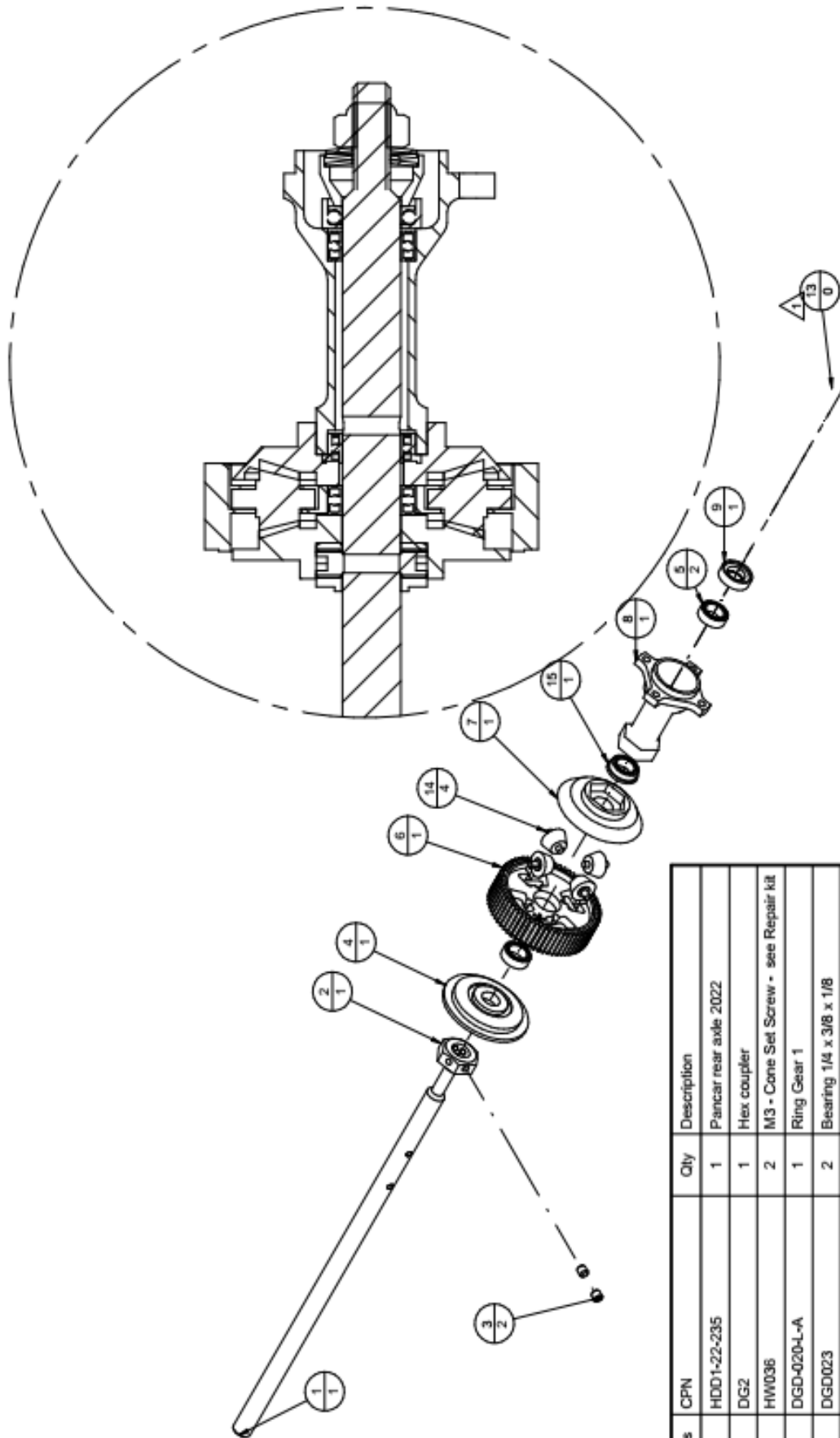

Repair kit: DGD022-Mk2

FENIX GEAR DIFF 235mm PANCAR - MK2

Pos	CPN	Qty	Description
1	HDD1-22-235	1	Pancar rear axle 2022
2	DG2	1	Hex coupler
3	HW036	2	M3 - Cone Set Screw - see Repair kit
4	DGD-020-L-A	1	Ring Gear 1
5	DGD023	2	Bearing 1/4 x 3/8 x 1/8
6	DGD-001-##	1	Spur Gear
7	DGD-020-L-B	1	Ring Gear - Light version
8	T1-2022-235	1	Left Hub Gear Diff 2022
9	FX0043A	1	Fenix Thrust Bearing
14	DGD006	4	satellite
15	FX14-38	1	Ball Bearing Flanged 3/8"x1/4"
16*	T2	1	Belleville holder - see Repair kit
17*	FD12-4	3	Diff Spring - see Repair kit
18*	HW006	1	Self locking nut M4 - standard

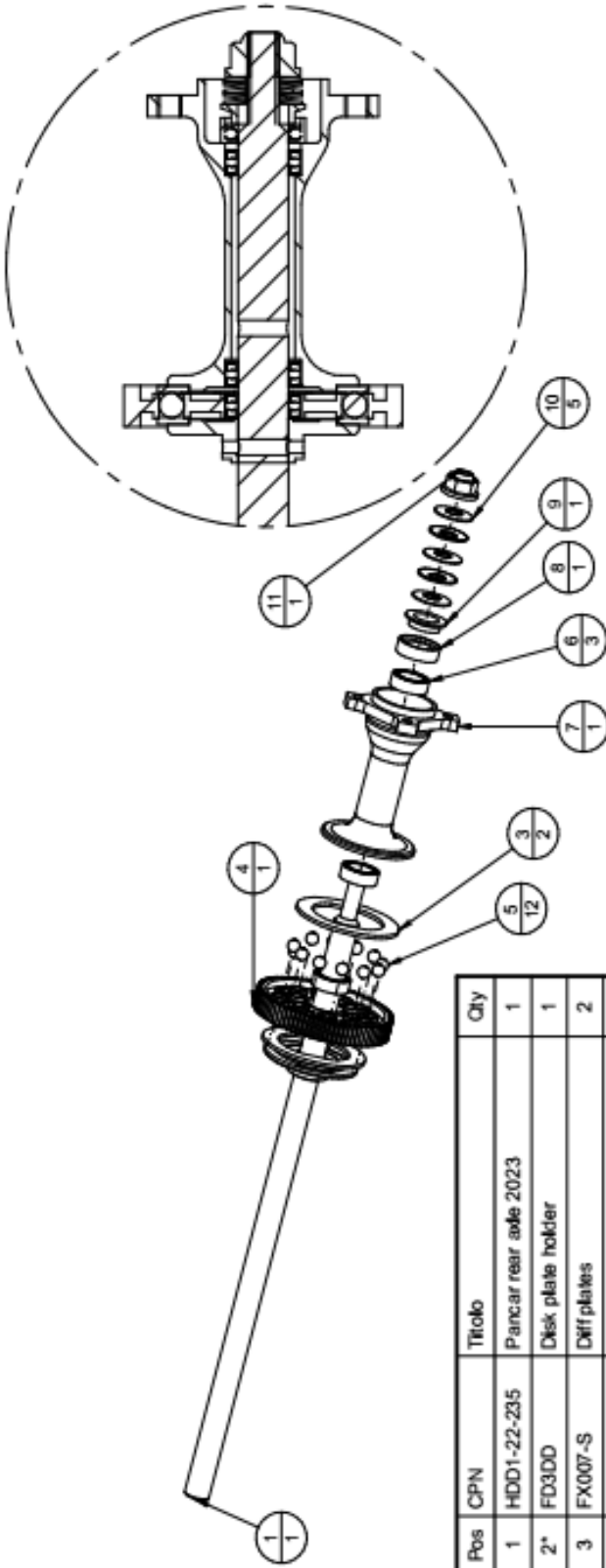

**FENIX HDD SPHERE DIFF
235mm PANCAR - MKZ**

Pos	CPN	Tiolo	Qty
1	HDD1-22-235	Pancar rear axle 2023	1
2*	FD3DD	Disk plate holder	1
3	FX007-S	Diff plates	2
4	K146	Spur Gear	1
5	FX0043C	Ceramic Sphere	12
6	DGD023	Bearing 1/4 x 3/8 x 1/8	3
7	HDD2-2-RH 235	Aluminium diff Hub	1
8	FX0043A	Fenix Thrust Bearing	1
9	T2- test	Spring Holder New F1 + Pro10	1
10	FD12-4	Diff Spring - see Repair kit	5
11	HW035	Self locking nut M4 - Flanged	1

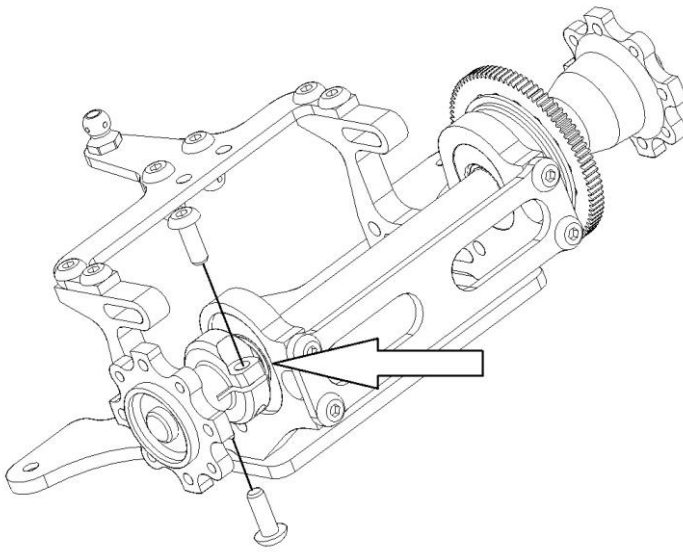

Slide the left hub HDD4 on the rear axle, leave 0.1-0.2mm of axial play.
Clamp it on the axle using 2 x HW008 3x8 button screws

Tech area

G56.2 allow several different major setting, according their main chassis

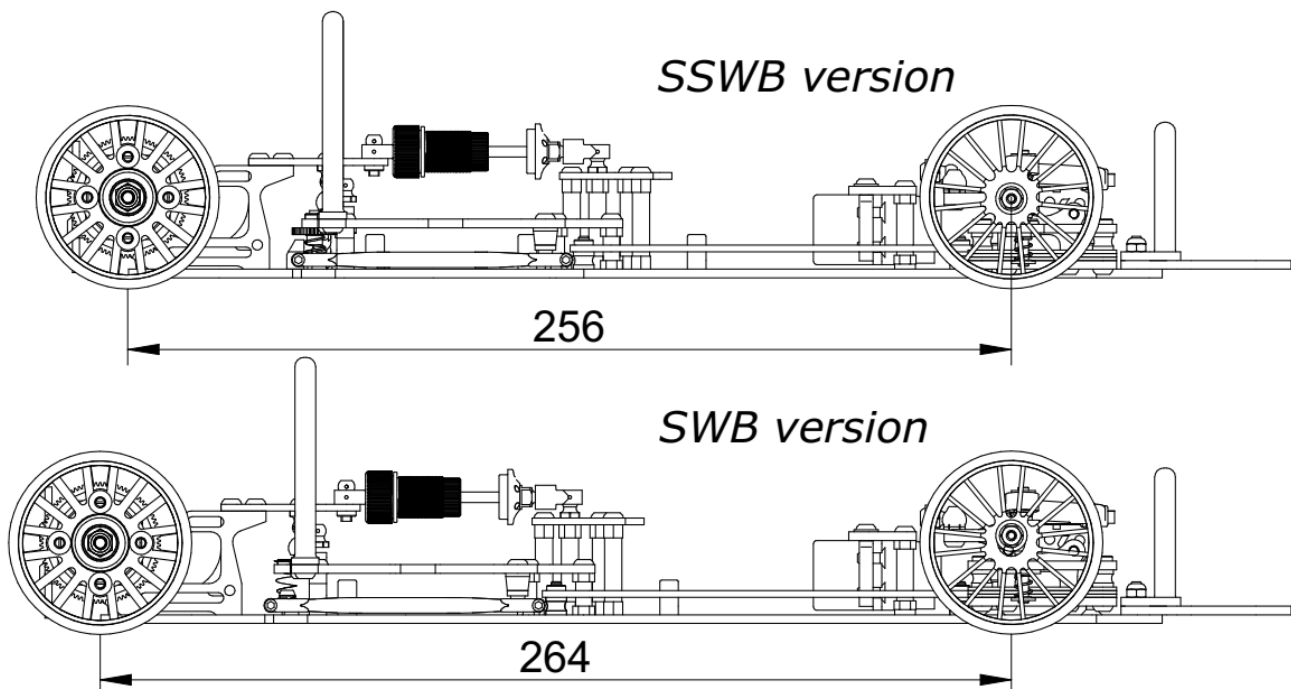

Tech area

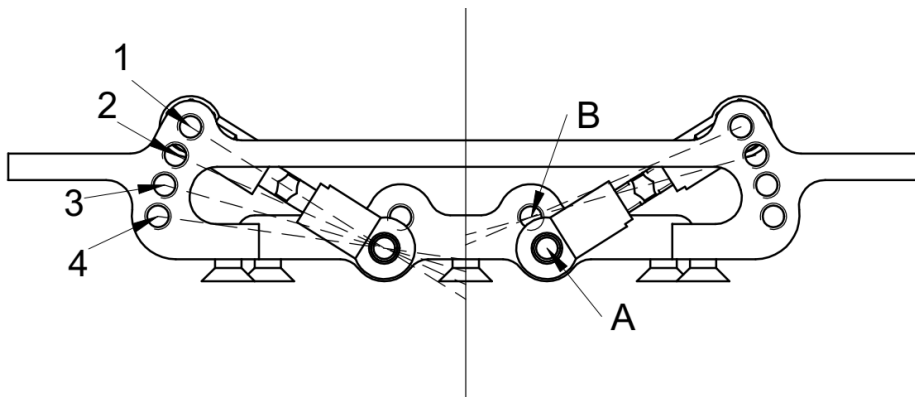

Roll center position
 B2
 B1
 A4
 A3
 A2
 A1

V-Link suspension has the unique ability to alter the roll centre position.

You can alter significantly the amount of rear grip by changing the roll centre position.

B2 is very much like a common pivot rear suspension.

A1 give the lowest roll centre.

Most of the time, you'll find a very comfortable setting using A2 or A3 position

Of course the 2 connection link must have the same length!!!

Here you can see how to set the V-link!

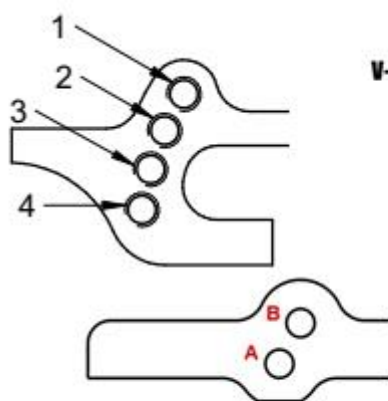

V-Link Guide

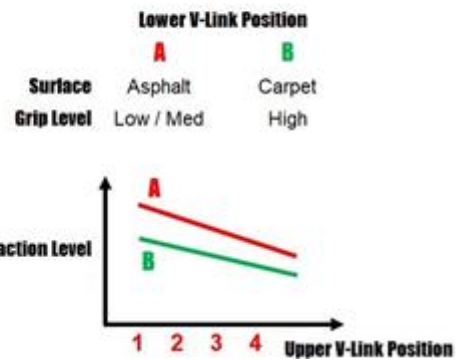

As rule of thumb, low to normal grip = A, normal to high = B

V-link suspension, has the ability to handle a certain degree of self steering, this can be “phased” or “counter phased”

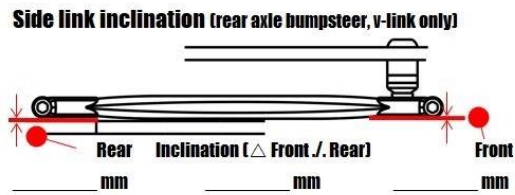

Positive Inclination (front higher)

negative bumpsteer: the outer wheel goes into a toe-out position, hence generating more steering (a tighter turning radius)

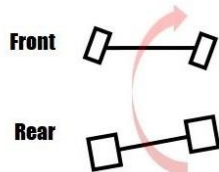

- + increase corner speed under high grip conditions
- + increase mid-corner steering

- loose rear end at corner entry under low grip conditions
- reduced traction at corner exit

Negative Inclination (rear higher)

positive bumpsteer: the outer wheel goes into a toe-in position and stabilizes the rear end

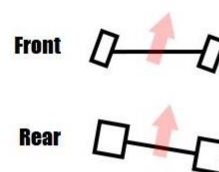

- + increase traction under low- or medium grip conditions
- + avoid snap-oversteer

- car tends to push at corner entry
- reduced on-power steering

Millimetre per revolution aka Rollout

Pancar (1/10 – 1/12) are using foam tires, where ratio need to be adjusted after each run, the system is MM (millimeter) Per Revolution aka Rollout.

It means you want to check how many mm the motor move each revolution.

You need to know:

Diameter of tire (easy take your Vernier and check it...):

Spur size and Pinion size

Diameter x 3.14 = perimeter

Tire diameter 56 x 3.14 = 175.84mm ok... keep it..

Spur / pinion 81 / 26 = 3.11

$175.84 / 3.11 = 56.54\text{mm}$ - Each turn of your motor, your car will travel 56.54mm

Rule of thumb: 13.5 – 2S – to timing/blinky mode

Indoor between 50-55mm,

Outdoor between da 65-75,

Huge 1/8 tracks 80mm

Rule of thumb: 4.5 – 2S

Outdoor starting point 45mmpr check temp often during the setup

There are a bunch of free app to be downloaded on your smartphone... Check for instance “Gears”, made by Nor-Cal Hobbies, Here you can download "Gears"

<https://play.google.com/store/apps/details?id=com.seamusoft.gears&hl=it>

Stay in touch with us!

Facebook
Old page... Hacked...



Facebook
New page!



Instagram



Twitter



Youtube



Fenix-Racing



Fenix racing shop

