

***FENIX REFERENCE G12***

***FENIX***

***REFERENCE G12***

Rev. 0.2.1

October 2020



# FENIX REFERENCE G12

REFERENCE G12 is an high-competition, high-quality, 1/10-scale model car intended for persons aged 16 years and older with previous experience building and operating RC model racing cars. This is not a toy; it is a precision racing model. This model racing car is not intended for use by beginners, inexperienced customers, or inexperienced racers or by children without direct supervision of a responsible, knowledgeable adult.

Before building and operating your REFERENCE G12, YOU MUST read through all of the operating instructions and instruction manual and fully understand them to get the maximum enjoyment and prevent unnecessary damage. Read carefully and fully understand the instructions before beginning assembly.

Contents of the box may differ from pictures. In line with our policy of continuous product development, the exact specifications of the kit may vary without prior notice.

Take appropriate safety precautions prior to operating this model. You are responsible for this model's assembly and safe operation! Please read the instruction manual before building and operating this model and follow all safety precautions

## IMPORTANT NOTES – GENERAL

- This product is not suitable for children under 16 years of age without the direct supervision of a responsible and knowledgeable adult.
  - Carefully read all manufacturers warnings and cautions for any parts used in the construction and use of your model.
  - Assemble this kit only in places away from the reach of very small children.
  - First-time builders and users should seek advice from people who have building experience in order to assemble the model correctly and to allow the model to reach its performance potential.
  - Exercise care when using tools and sharp instruments.
  - Take care when building, as some parts may have sharp edges.
  - Keep small parts out of reach of small children. Children must not be allowed to put any parts in their mouth, or pull vinyl bag over their head.
  - Read and follow instructions supplied with paints and/or cement, if used (not included in kit).
  - Immediately after using your model, do NOT touch equipment on the model such as the motor and speed controller, because they generate high temperatures. You may seriously burn yourself seriously touching them.
  - Follow the operating instructions for the radio equipment at all times.
  - Do not put fingers or any objects inside rotating and moving parts, as this may cause damage or serious injury as your finger, hair, clothes, etc. may get caught.
  - Be sure that your operating frequency is clear before turning on or running your model, and never share the same frequency with somebody else at the same time. Ensure that others are aware of the operating frequency you are using and when you are using it.
  - Use a transmitter designed for ground use with RC cars. Make sure that no one else is using the same frequency as yours in your operating area. Using the same frequency at the same time, whether it is driving, flying or sailing, can cause loss of control of the RC model, resulting in a serious accident.
  - Always turn on your transmitter before you turn on the receiver in the car. Always turn off the receiver before turning your transmitter off.
  - Keep the wheels of the model off the ground when checking the operation of the radio equipment.
  - Disconnect the battery pack before storing your model.
  - When learning to operate your model, go to an area that has no obstacles that can damage your model if your model suffers a collision.
  - Remove any sand, mud, dirt, grass or water before putting your model away.
  - If the model behaves strangely, immediately stop the model, check and clear the problem.
  - To prevent any serious personal injury and/or damage to property, be responsible when operating all remote controlled models.
  - The model car is not intended for use on public places and roads or areas where its operation can conflict with or disrupt pedestrian or vehicular traffic.
  - Because the model car is controlled by radio, it is subject to radio interference from many sources that are beyond your control. Since radio interference can cause momentary loss of control, always allow a safety margin in all directions around the model in order to prevent collisions.
  - Do not use your model:
    - Near real cars, animals, or people that are unaware that an RC car is being driven.
    - In places where children and people gather
    - In residential districts and parks
    - In limited indoor spaces
    - In wet conditions
    - In the street
    - In areas where loud noises can disturb others, such as hospitals and residential areas.
    - At night or anytime your line of sight to the model may be obstructed or impaired in any way.
- To prevent any serious personal injury and/or damage to property, please be responsible when operating all remote controlled models. Failure to follow these instructions will be considered as abuse and/or neglect.
- We have made every effort to make these instructions as easy to understand as possible. However, if you have any difficulties, problems, or questions, please do not hesitate to contact the Fenix support team at [racing@fenixwaterjet.com](mailto:racing@fenixwaterjet.com) . Also, please visit our Web site at [www.Fenix-racing.com](http://www.Fenix-racing.com) or [www.fenixracingshop.com](http://www.fenixracingshop.com) or <https://www.facebook.com/FenixRacing.it/> the latest updates, set-up information, option parts, and many other goodies. We pride ourselves on taking excellent care of our customers.

Just a quick note.... Read the manual "before" and not after....



# FENIX REFERENCE G12

Servo is not included, Reference G12 need a Mini servo.

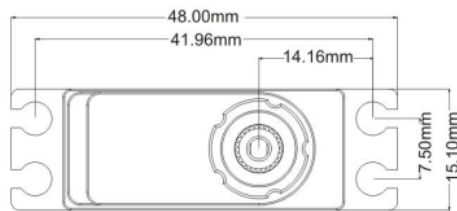

Note the dimension of the servo suggested

You can also use Sanwa servo, with the special servo holder.

Please note that the Sanwa holder is provided as option, or special version for certain market.

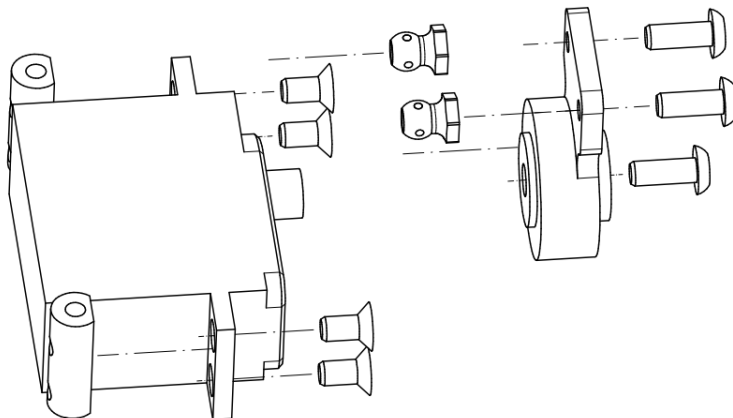
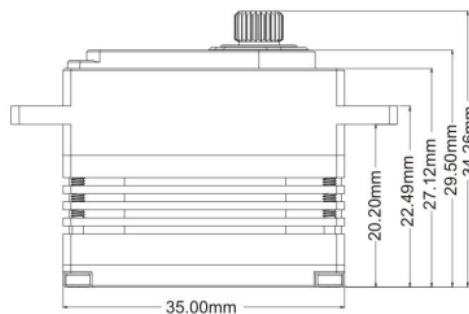

Use the 2 x HW003 M3x8mm button to secure the FX-FU48 to the servo saver. Use the 4 x HW012 M3x6 countersunk screw to fix the FX022 servo mount

Note: Servo and Ball stud position affect Ackerman angle. Use it as setup option.

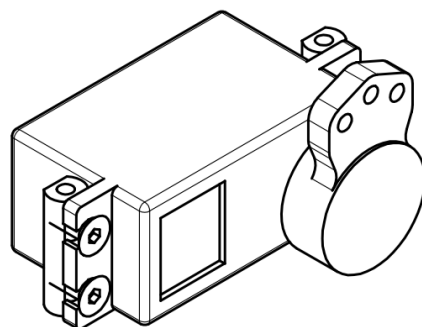

Assembled group. Servo saver should be vertical when servo is neutral.

# FENIX REFERENCE G12

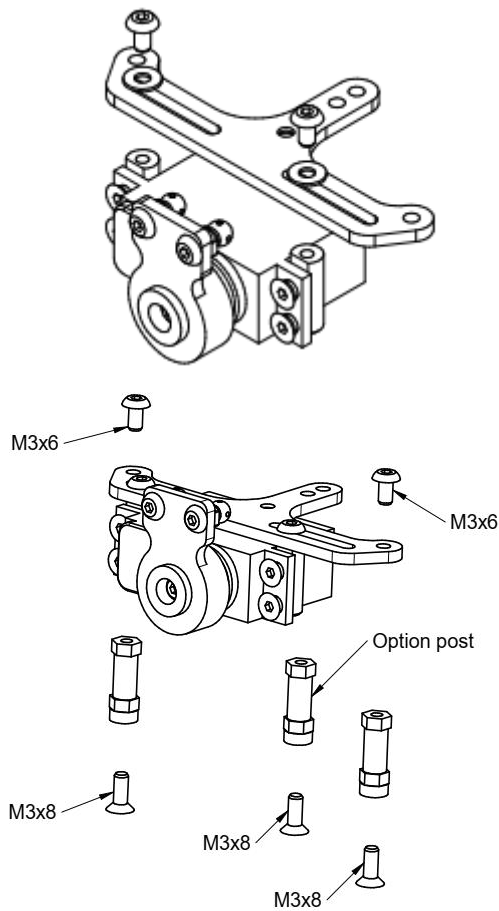

Using 2 x HW008 M3x6 Button, fix the servo group to the G12-7 servo holder.

Insert 2 washer under the M3x6 screws

Take care to centre the servo saver toward the servo holder.

**Note:**

Servo is held in place by 2 (or 3 )15mm post, according your servo and chassis setting.

Fix the servo group to the chassis using 15mm post

Insert the FX0074 3mm shims under the 15mm post

Fix the group to the chassis (omitted in the view) with HW007 M3x8 screws

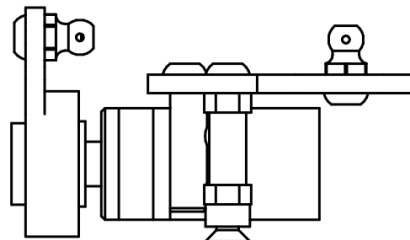

If you are using the 2 post system you can install the FU-FX48 using the M3x6 HW008 Button screw.

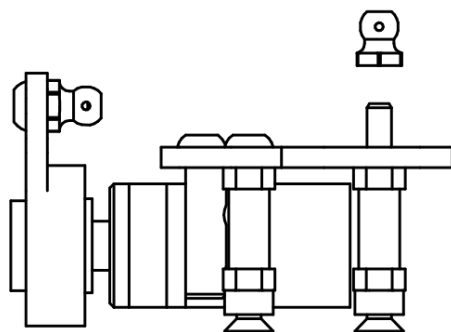

If you are using the 3 post system you can install the FU-FX48 using the M3x10 grub screw.

# FENIX REFERENCE G12

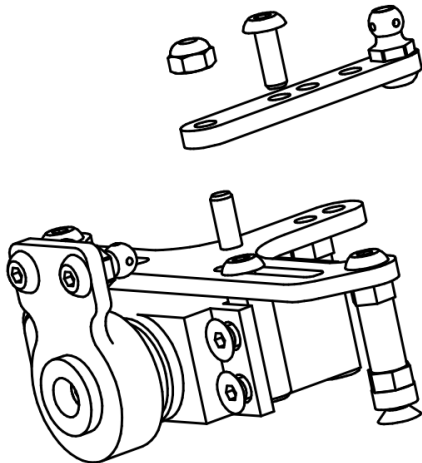

There is an optional shock locator which allow to use the damper with a more gentle angle and with several different shock locations.

To use this insert the HW033 M3x10 countesink hole, insert the G12-8 shock holder and fix it with the M3 nylock.

Insert the M3x10 Hw004 in the 15mm post and fix it.

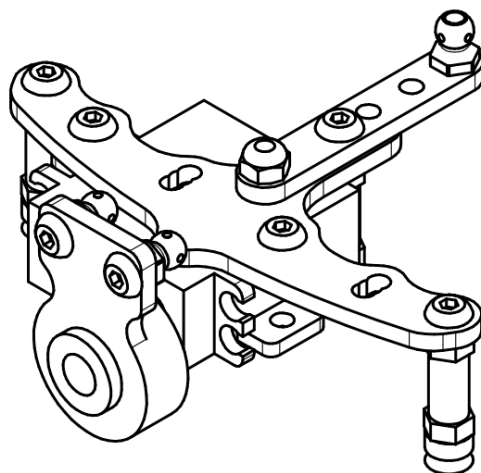

When you use the Sanwa option, the fully option group, will look like this one

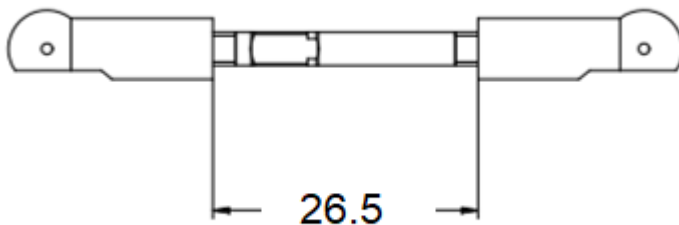

Using the CRC from bag A made 2 turnbuckles as show

Note: use CRC plastic ball cup on the steering block together the CRC red low profile ball.

Note: for you comfort, pre-thread both plastic ball cup before assembly the turnbuckles

Fenix plastic ball cup and FX-FU48 are to be used on servo saver

## Bag C

Motor Pod

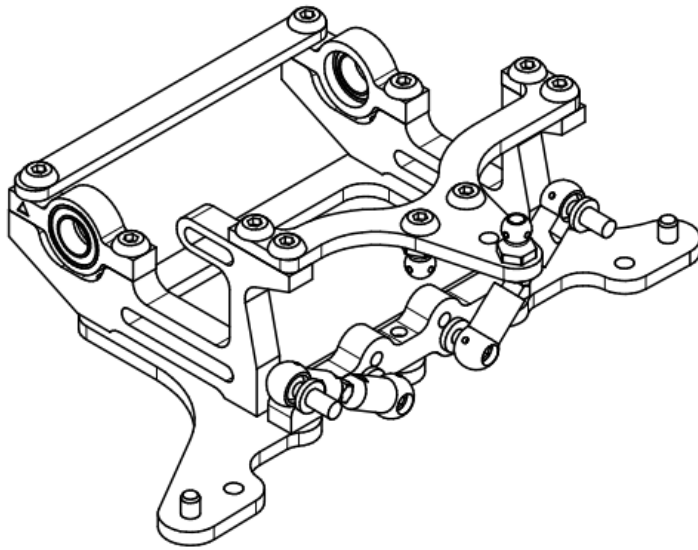

### NOTE:

Before start to assembly the rear end of Reference G12, we strongly suggest you, to visit the Fenix Racing Youtube channel and look the "V-link suspension setup" video, here is the link.

<https://www.youtube.com/watch?v=SEwNQcn12A0>

There, you'll also found some video useful when dealing with the Fenix Gear Diff.

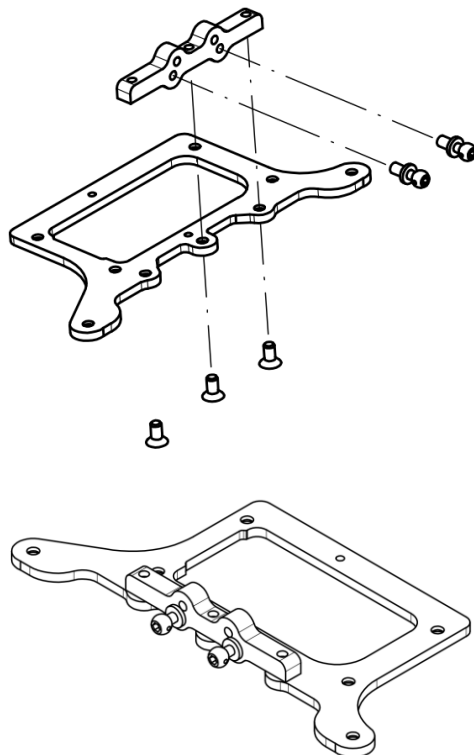

Using 3 x HW012 M3x6 countersunk screw fix the V-link F2 to the motor pod.

Insert 2 x male ball stub into the V-link F2.

# FENIX REFERENCE G12

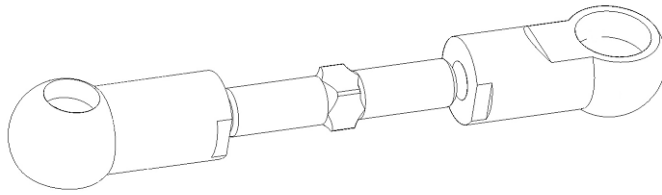

Build 2 set of link using  
2 x TR15 and 4 FX0037  
- short

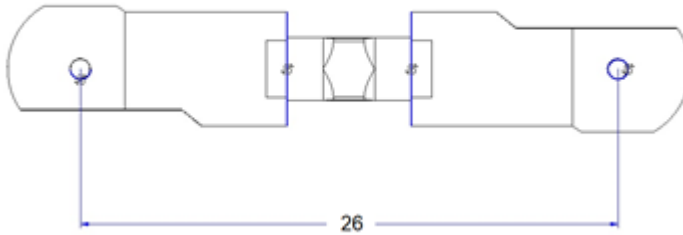

Keep this dimensions.  
Fix the link over the V-  
link F2

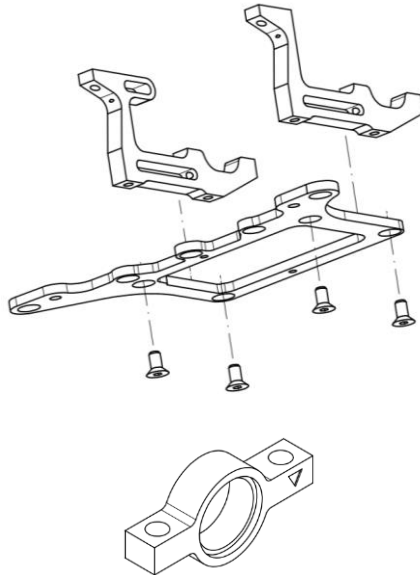

Using 4 x HW012  
countersunk screws,  
fix the motor holder to  
the motor pod.

Tight the screws evenly  
using an "X" pattern

Note: V-Link F2 is  
omitted for sake of  
clarity.

Insert the bearing into  
the G12-C bearing  
holder.

Note that the mark  
should be on the same  
position (vertex NOT  
important) .

G12-C allow you play  
with the wheelbase  
giving +1mm



# FENIX REFERENCE G12

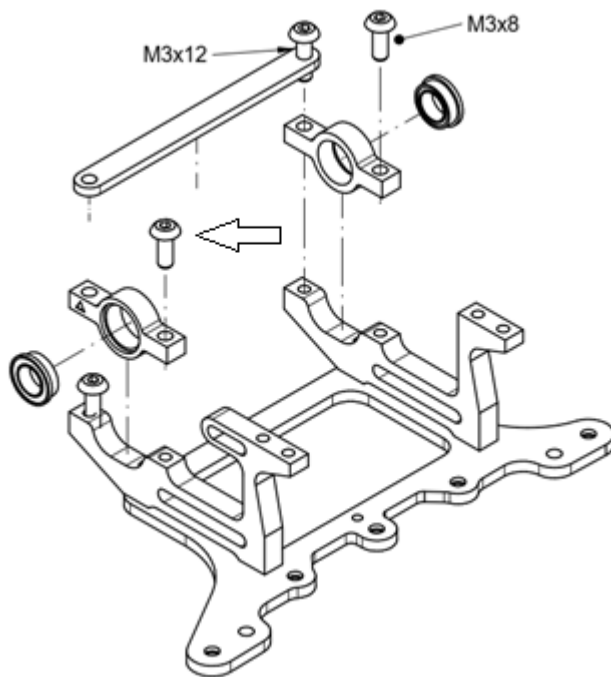

Fix the G12-C to the bulkheads with 2 HW003 M3x8 button screw in the front holes.

Rear holes, you need to install the G12-10 brace and fix brace and G12-C using HW029 M3x12 button screws.

Tight the screws evenly using an "X" pattern

Note: the arrow show a screw that might interfere with some motors. Please check.

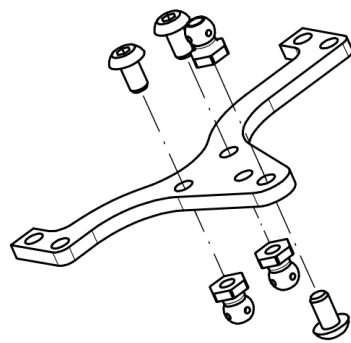

Use the provided HW008 M3x6 button screw to install the ball stud to the shock holder.

Note: Wait to install the shock holder to the motor group.

Note:

Option for the Alu version.

Insert 2 x 0.5mm shims under the link sphere.

Not included in the carbon version

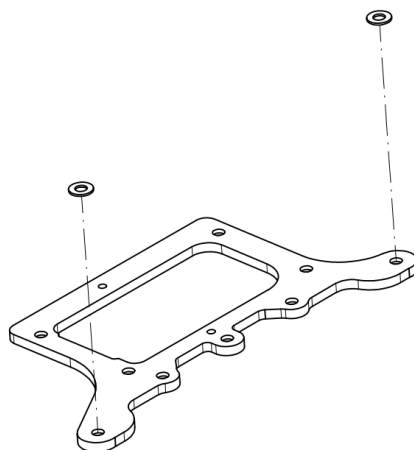

How about a cup of coffee now? You deserve it!

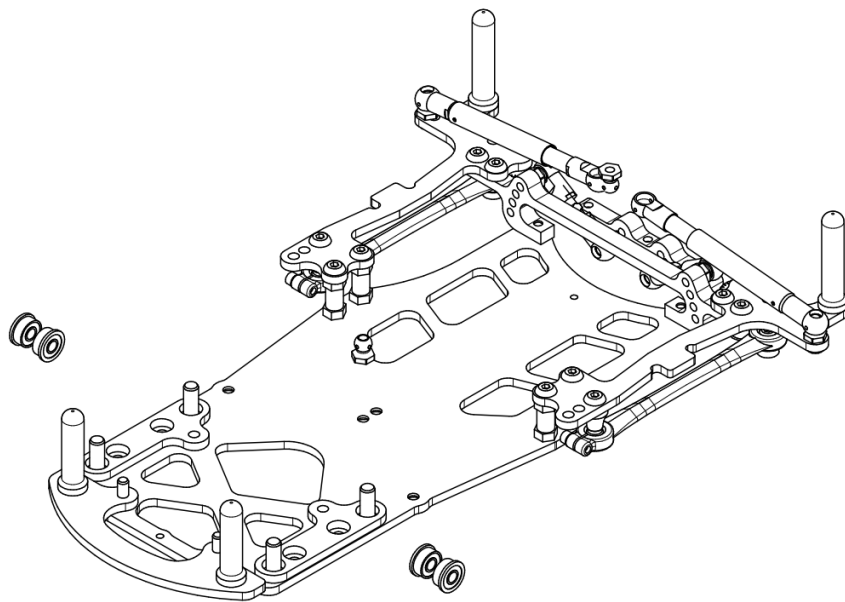

## Bag D

Rear V-link and  
common parts

# FENIX REFERENCE G12

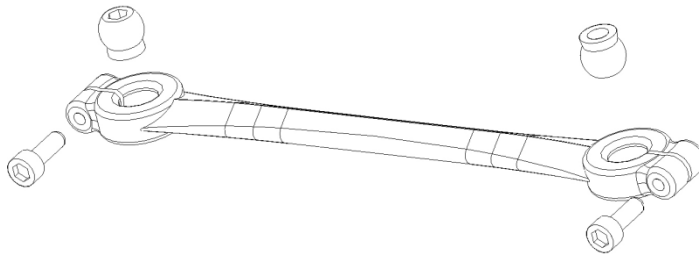

Spring holder



OR



Prepare 2 sets – note the position of the spheres.

Use 2 x HW0014 M2x 6 screws and 2 x FX002 spheres each

**Note:** *spring holder might have 2 different shape. Hex one or round one.*

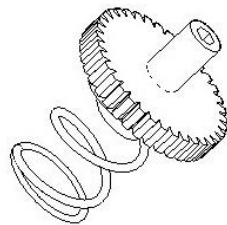

Grub screw M3 x 8

Prepare 2 side spring group set as shown

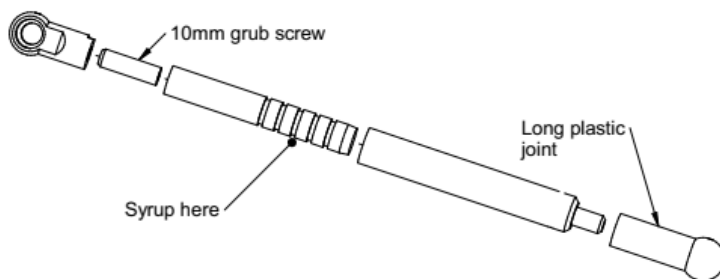

Assembly the 2 side dampers as shown

# FENIX REFERENCE G12

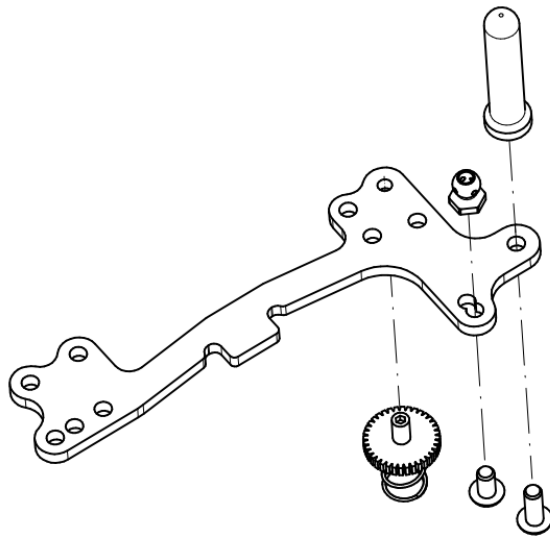

Prepare 2 **mirror** like side element, using G12-3

Fix the body post using 1 HW003 M3x8 button screw.

Fix the FU-FX48 using 1 HW008 M3x6 button screw.

Insert the side spring group into the carbon fibre

**Note:**

Use special attention when “thread” the grub screw in the carbon fibre, lubricate the grub screw often during the operation and insert it slowly.

You might want to thread the carbon fibre using an M3 tap.

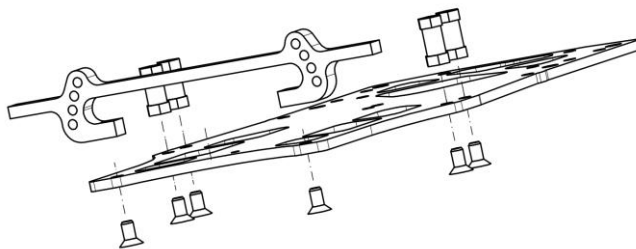

Install 4 x FX0052 12mm post, using 4 x HW003 M3x8 countersunk

Install the V-link F1 using 2 x HW008 M3x6 countersunk screw

Install the side group as shown using 4 x HW003 M3x6 button screws and 4 HW003 M3x8 button screw.

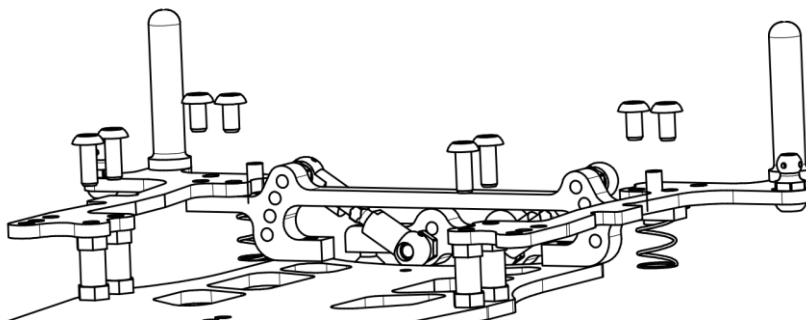

# FENIX REFERENCE G12

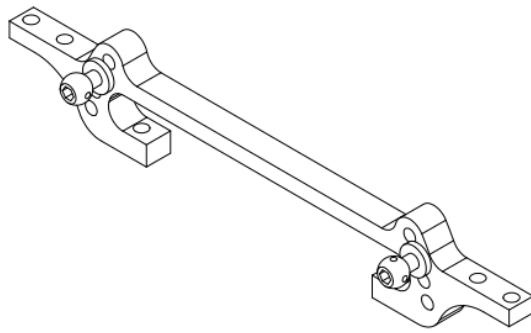

From Bag C, insert 2 x male stud.  
Fix the short link between V-link F1 and V-link F2

## Note

Please, check in the tech section about the V-link settings.  
Install the side link you've prepared before using 1 HW029 M3x12 button screw.  
Insert the G56042 spacer between the carbon side wing and the link.  
Use 2 x 2mm allen to tight the sphere link.

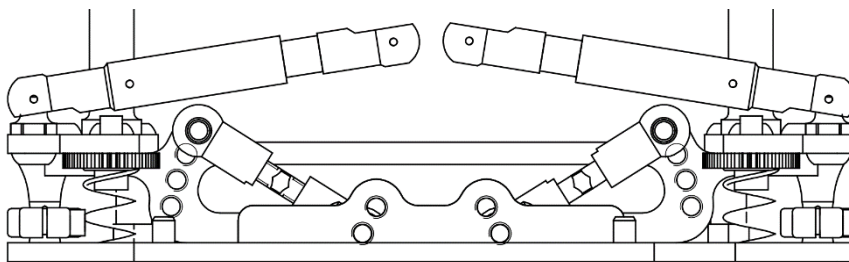
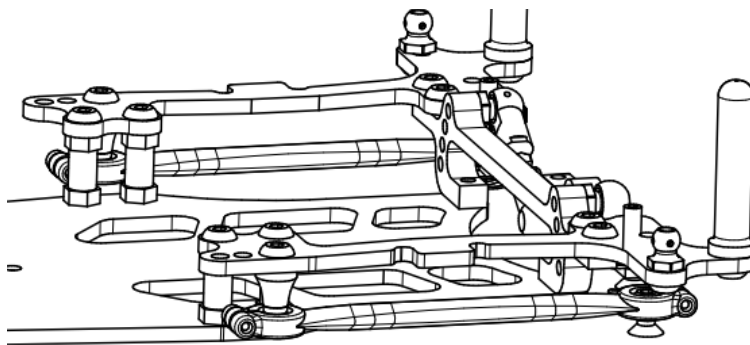

Now, lay the car on a flat setup board and make the final fine tuning of the links length. Chassis and motor pod must lay flat on the setup board.

Take the proper time for this setting.

Check our channel on Youtube for some explicative video.

<https://www.youtube.com/channel/UCDZqN09hr2Eal7qHCMjUcjQ>

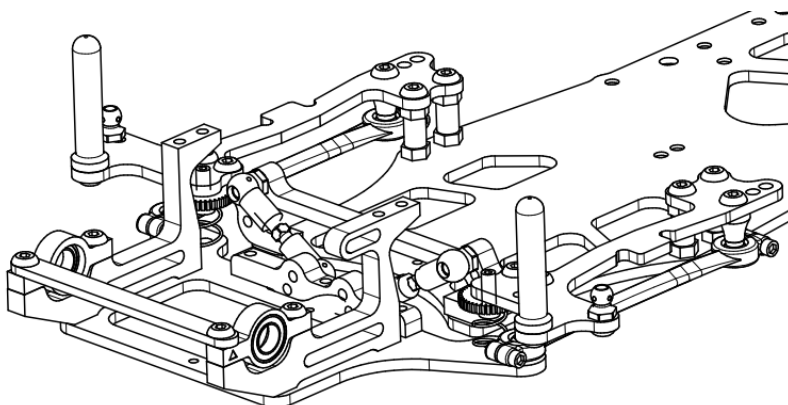

Now you can couple the motor pod to the chassis group.

Side links can be installed using 2 x HW012 M3x6.

# FENIX REFERENCE G12

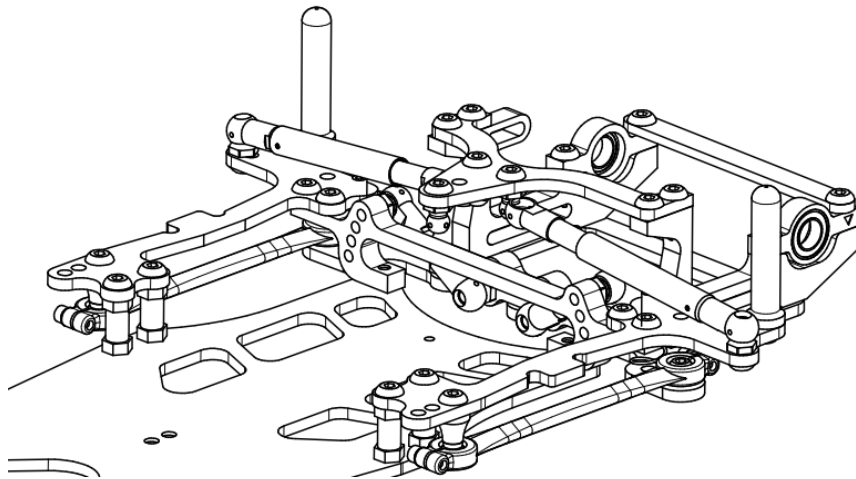

Install the G12-4 shock holder, using 4 by HW008 3x6 button screw

Install now the side dampers

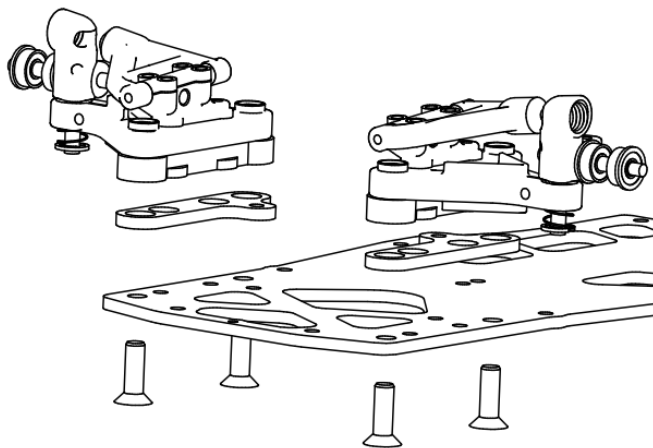

Install the CRC front end using 4 by G12-K1 8-32" Titanium screws

Insert between the chassis and the front end the G12-6 shims

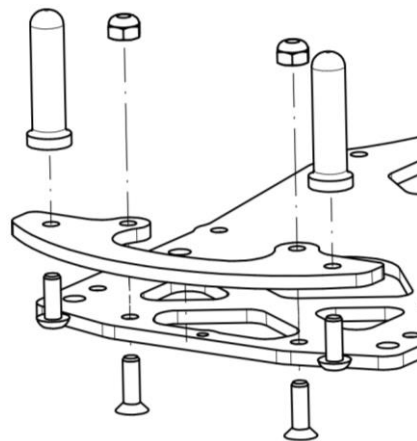

Install the front body post to the bumper using 2 x HW003 M3x8 button screws.

Fix the bumper to the chassis using 2 x HW004 M3 x 10 countersunk screws and M3 Nylocks

Bag E

Differential

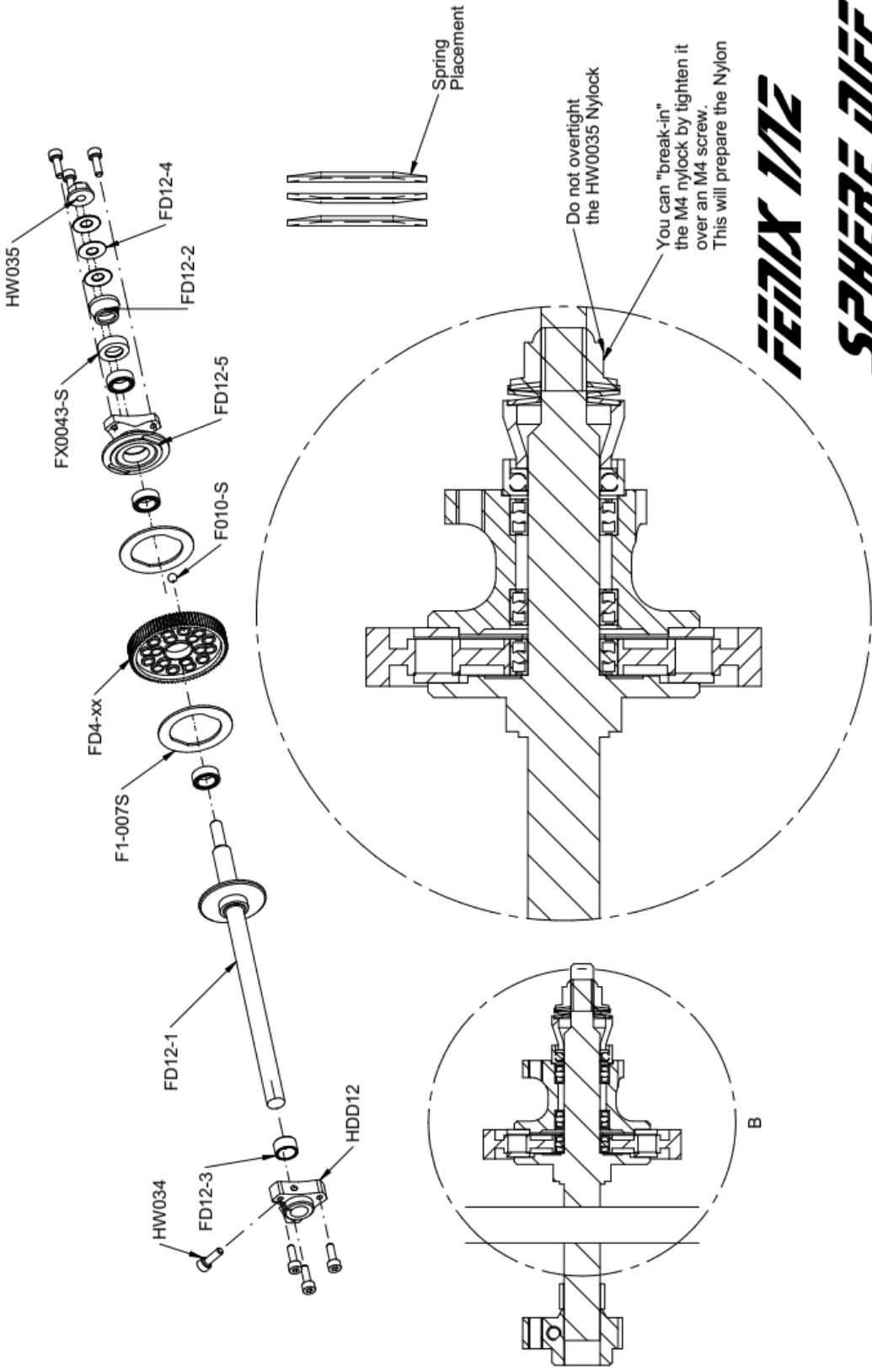

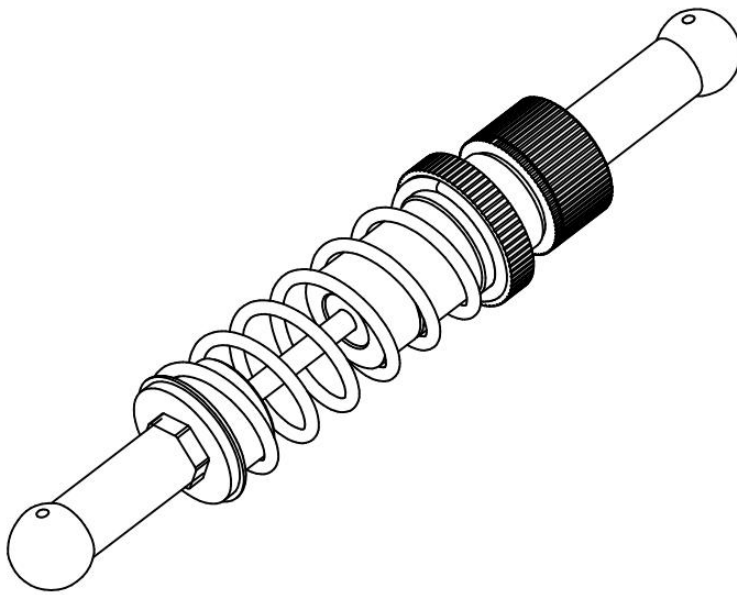

## Bag F

Shock Absorber

**Step 1:**  
Slide 1 E-Clip over the shock shaft  
Insert the piston  
Slide the second E-Clip over the shock shaft

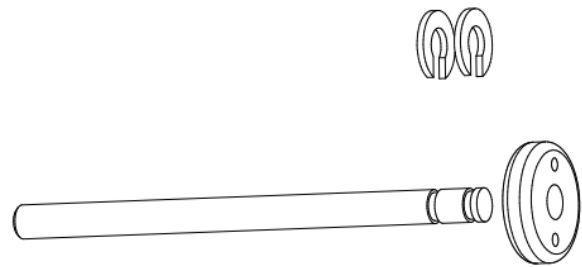

**Step 2:**  
Insert the O-ring into the preload nut

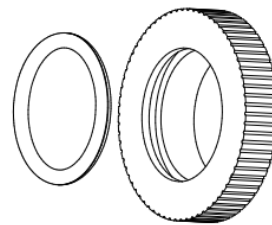

**Step 3:**  
Insert the preload nut onto the shock body.  
Take your time and not cross thread the nut  
over the body.

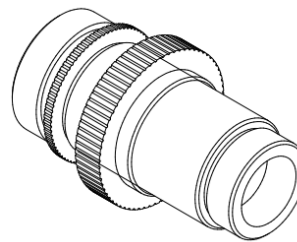

### Tip:

You might want to cut about 1/2 from the  
oring. This will make the job much easier



# FENIX REFERENCE 612

## Step 4:

Lube the 2x6mm oring with some shock oil or diff grease, insert it into the recess.

Lube the plastic insert with some shock oil or diff grease, insert it into the recess, over the oring.

Tight the bottom nut

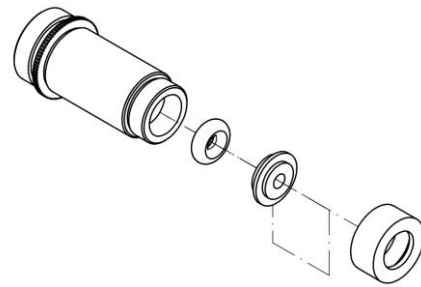

## Step 5:

Lube the shock shaft with some shock oil and insert it into the shock body

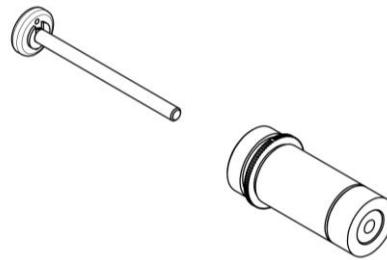

## Step 6:

Fill the shock with your favorite shock oil and bleed the air bubbles moving the shaft up – down slowly

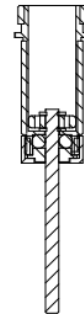

## Step 7:

Install the shock bladder and tight the upper cap.

Clean the excess of oil



## Step 8:

Install the spring and the shock bottom mount. Secure it on the shaft with the M3x3 set screw

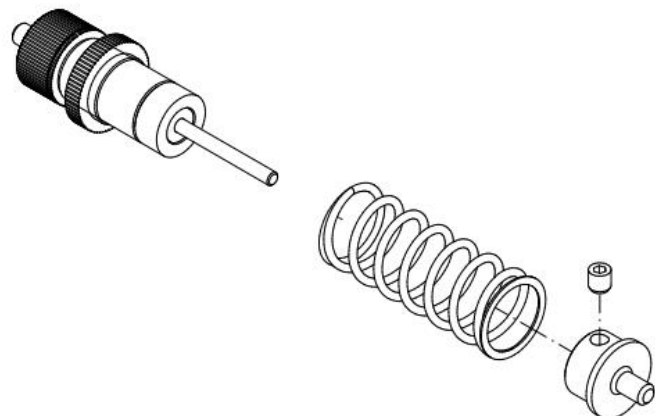

## Tech area

REFERENCE G12 represent a major breakthrough in the 1/12 class. Nothing comes close to this 1/12 model.

We've had several drivers developing the car, from Club racers to ETS and Nationals A-main finalist, and we'd like to thank all of them for the time and dedication they put in this project.

**Front End:** Choosing the proven CRC 1/12 front end, allows you to use an easy and proven front end system that allows you to alter camber, caster and dynamic caster.

**Rear End:** V-link: we spent quite a lot of time developing this rear end, using different brand of tires, driving on carpet and asphalt.

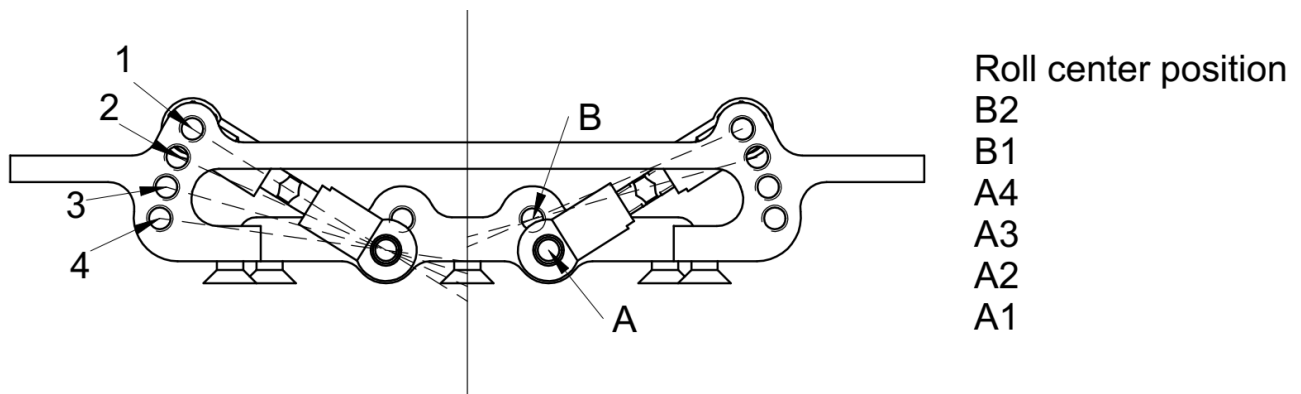

V-Link suspension has the unique ability to alter the roll centre position.

You can alter significantly the amount of rear grip by changing the roll centre position.

B2 is very much like a common pivot rear suspension.

A1 give the lowest roll centre.

Most of the time, you'll find a very comfortable setting using A2 or A3 position

*Of course the 2 connection link must have the same length!!!*

## **Millimetre per revolution aka Rollout**

Pancar (1/10 – 1/12) are using foam tires, where ratio need to be adjusted after each run, the system is MM (millimeter) Per Revolution aka Rollout.

It means you want to check how many mm the motor move each revolution.

You need to know:

Diameter of tire (easy take your Vernier and check it...) :

Spur size and Pinion size

Diameter x 3.14 = perimeter

Tire diameter 41 x 3.14 = 128,74mm ok... keep it..

Spur / pinion 81 /26 = 3.11 (gear ratio)

$128,74/3.11 = 41.39\text{mm}$

This means that every time your motor spins, the rear wheel makes 41.39mm.

To keep constant the performance, you've to adjust the gear ratio according the wheel diameter.